

Inverter MICROMASTER 440



4/2	Description
4/4	Circuit diagrams
4/6	Technical data
4/9	Selection and ordering data
4/12	Options
4/26	Dimension drawings

MICROMASTER 440

Description



Application

The MICROMASTER 440 inverter is suitable for a variety of variable-speed drive applications. Its flexibility provides for a wide spectrum of applications. These also include cranes and hoisting gear, high-bay warehouses, production machines for food, beverages and tobacco, packaging machines etc.; i.e. applications which require the frequency inverter to have a higher functionality and dynamic response than usual.

The inverter is especially characterized by its customer-oriented performance and ease-of-use. Its large mains voltage range enables it to be used all over the world.

Design

The MICROMASTER 440 inverter has a modular design. The operator panels and modules can be easily exchanged.

International standards

- The MICROMASTER 440 inverter complies with the requirements of the EU low-voltage guideline
- The MICROMASTER 440 inverter has the **CE** marking
- acc. to **®** and **c®** certified
- c-tick **C**

Note:

- See Appendix for standards.

Main characteristics

- Easy, guided start-up
- Modular construction allows maximum configuration flexibility
- Six programmable isolated digital inputs
- Two scaleable analog inputs (0 V to 10 V, 0 mA to 20 mA) can also be used as a 7th/8th digital input
- Two programmable analog outputs (0 mA to 20 mA)
- Three programmable relay outputs (30 V DC/5 A resistive load; 250 V AC/2A inductive load)
- Low-noise motor operation thanks to high pulse frequencies, adjustable (observe derating if necessary)
- Complete protection for motor and inverter.

Options (overview)

- EMC filter, Class A/B
- LC filter and sinusoidal filter
- Line commutating chokes
- Output chokes
- Gland plates

- Basic Operator Panel (BOP) for parameterizing the inverter
- Plain text Advanced Operator Panel (AOP) with multi-language display
- Plain text Asian Advanced Operator Panel (AAOP) with Chinese and English display
- Plain text Cyrillic Advanced Operator Panel (CAOP) with Cyrillic, German and English display
- Communication modules
 - PROFIBUS
 - DeviceNet
 - CANopen
- Pulse encoder evaluation module
- PC connection kits
- Mounting kits for installing the operator panels in the control cabinet doors
- PC start-up tools executable under Windows 98 and NT/2000/ME/XP Professional
- TIA integration with Drive ES.

Mechanical features

- Modular design
- Operating temperature
0.12 kW to 75 kW:
-10 °C to +50 °C
(+14 °F to +122 °F)
90 kW to 200 kW:
0 °C to +40 °C
(+32 °F to +104 °F)
- Compact housing as a result of high power density
- Easy cable connection, mains and motor connections are separated for optimum electromagnetic compatibility
- Detachable operator panels
- Screwless control terminals on detachable I/O board.

Performance features

- Latest IGBT technology
- Digital microprocessor control
- High-quality Vector Control system
- Flux Current Control (FCC) for improved dynamic response and optimized motor control
- Linear V/f characteristic
- Quadratic V/f characteristic
- Multipoint characteristic (programmable V/f characteristic)
- Torque control
- Flying restart
- Slip compensation
- Automatic restart following mains failure or fault
- User-definable function blocks for logic and arithmetic operations
- Kinetic buffering
- Positioning ramp down
- High-grade PID controller for simple internal process control (autotuning)
- Programmable acceleration/deceleration, 0 s to 650 s
- Ramp smoothing
- Fast Current Limit (FCL) for trip-free operation
- Fast, repeatable digital input response time
- Fine adjustment using two high-resolution 10-bit analog inputs
- Compound braking for controlled rapid braking
- Integrated brake chopper (for 0.12 kW to 75 kW inverters)
- Four skip frequencies
- Removable "Y" capacitor for use on IT systems (with non-grounded mains supplies, the "Y" capacitor must be removed and an output choke installed).

Protection features

- Overload capability
 - **CT mode**
0.12 kW to 75 kW:
Overload current 1.5 x rated output current (i.e. 150 % overload capability) for 60 s, cycle time 300 s, and 2 x rated output current (i.e. 200 % overload capability) for 3 s, cycle time 300 s
 - 90 kW to 200 kW:
Overload current 1.36 x rated output current (i.e. 136 % overload capability) for 57 s, cycle time 300 s, and 1.6 x rated output current (i.e. 160 % overload capability) for 3 s, cycle time 300 s
 - **VT mode**
5.5 kW to 90 kW:
Overload current 1.4 x rated output current (i.e. 140 % overload capability) for 3 s, and 1.1 x rated output current (i.e. 110 % overload capability) for 60 s, cycle time 300 s
 - 110 kW to 250 kW:
Overload current 1.5 x rated output current (i.e. 150 % overload capability) for 1 s, and 1.1 x rated output current (i.e. 110 % overload capability) for 59 s, cycle time 300 s
- Overvoltage/undervoltage protection
- Inverter overtemperature protection
- Special direct connection for PTC or KTY to protect the motor
- Earth fault protection
- Short-circuit protection
- $\hat{I}t$ motor thermal protection
- Locked motor protection
- Stall prevention
- Parameter interlock.

MICROMASTER 440

Circuit diagrams

General circuit diagram

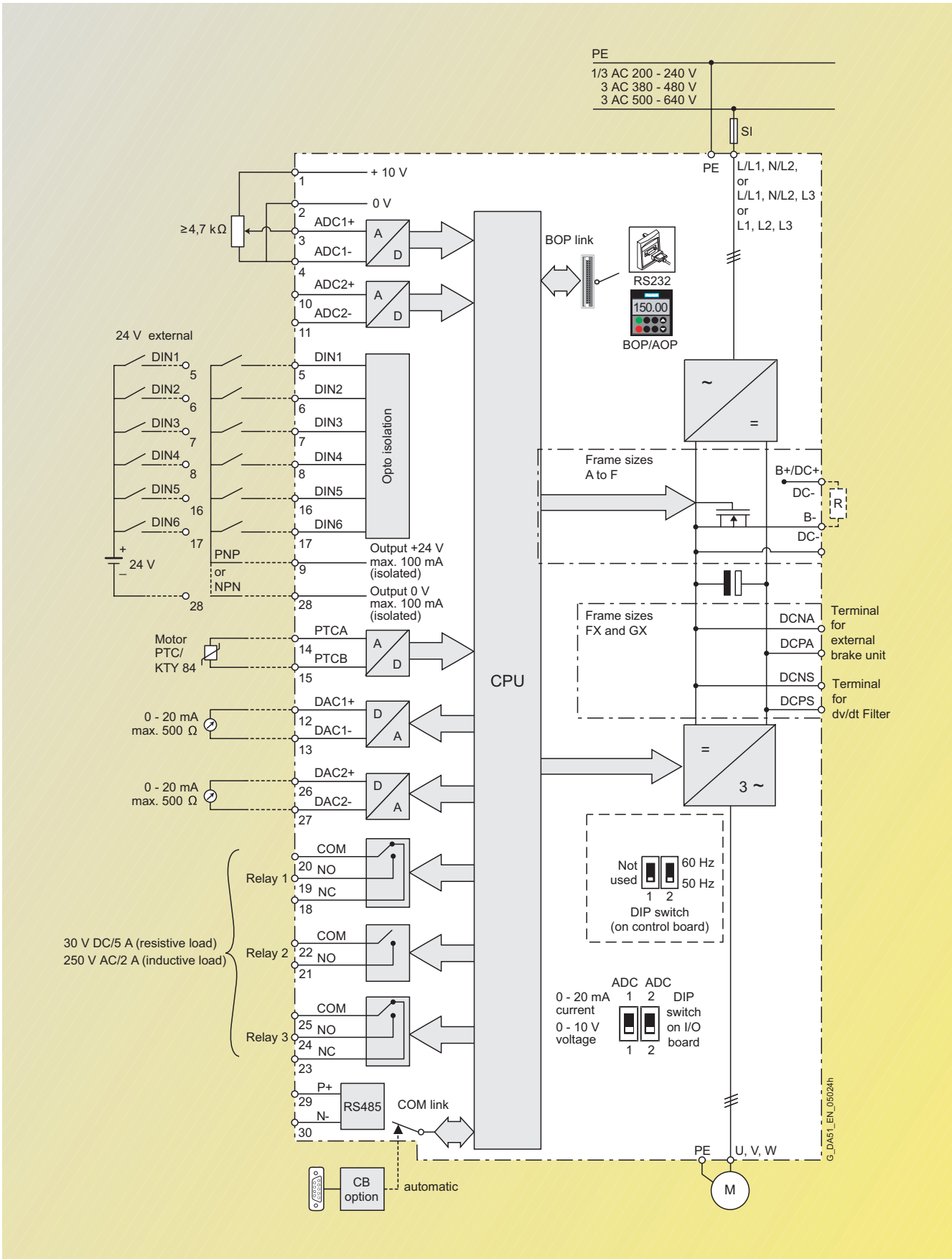

4

Terminal connection diagram

Example, frame size FX

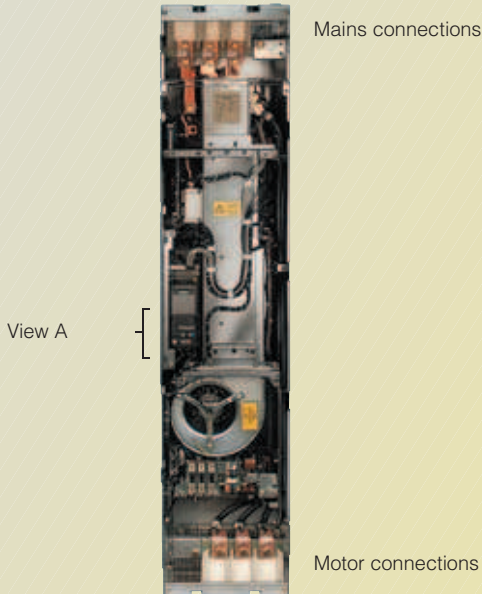

View A

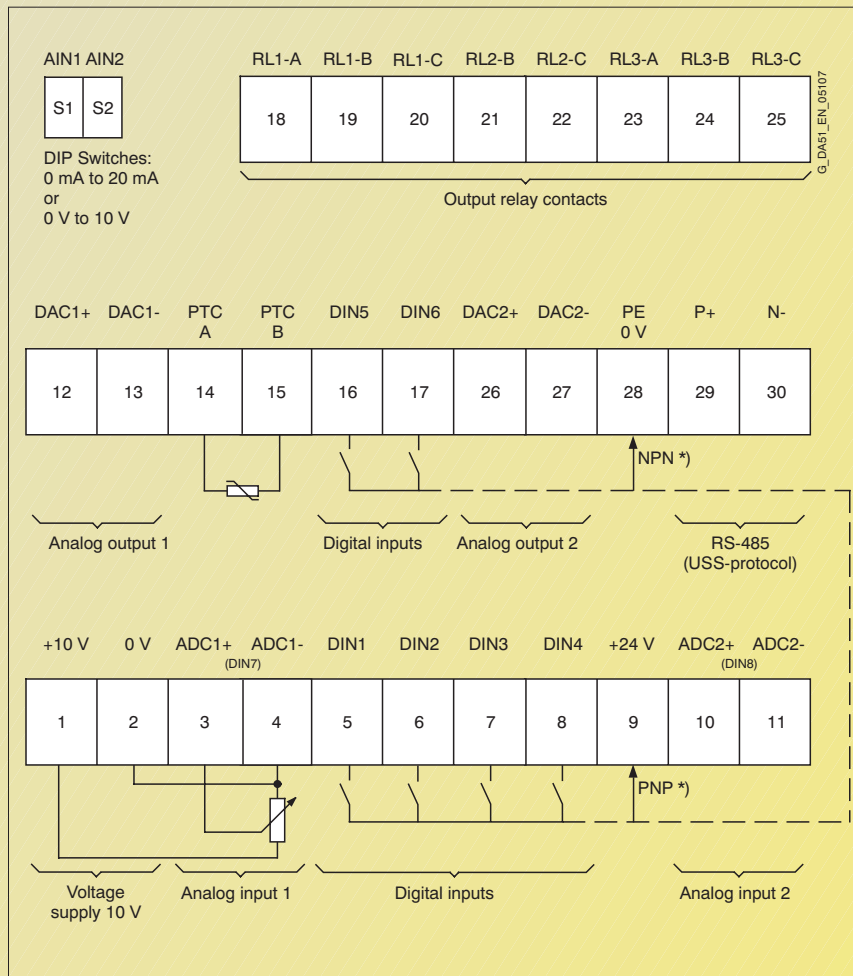

*) PNP or NPN possible

MICROMASTER 440

Technical data

MICROMASTER 440 inverter

Mains voltage and power ranges	1 AC 200 V to 240 V ± 10 % 3 AC 200 V to 240 V ± 10 % 3 AC 380 V to 480 V ± 10 % 3 AC 500 V to 600 V ± 10 %	CT (constant torque) 0.12 kW to 3 kW 0.12 kW to 45 kW 0.37 kW to 200 kW 0.75 kW to 75 kW	VT (variable torque) – 5.5 kW to 55 kW 7.5 kW to 250 kW 1.5 kW to 90 kW
Input frequency	47 Hz to 63 Hz		
Output frequency	0.12 kW to 75 kW 90 kW to 200 kW	0 Hz to 650 Hz (in V/f mode) 0 Hz to 267 Hz (in V/f mode)	0 Hz to 200 Hz (in vector mode) 0 Hz to 200 Hz (in vector mode)
Power factor	≥ 0.95		
Inverter efficiency	0.12 kW to 75 kW: 96 % to 97 %; 90 kW to 200 kW: 97 % to 98 % (Further information is available on the Internet at: http://support.automation.siemens.com/WW/view/en/22978972)		
Overload capability	0.12 kW to 75 kW 90 kW to 200 kW	Overload current 1.5 x rated output current (i.e. 150 % overload capability) for 60 s, cycle time 300 s and 2 x rated output current (i.e. 200 % overload capability) for 3 s, cycle time 300 s	
– CT mode	5.5 kW to 90 kW 110 kW to 250 kW	Overload current 1.36 x rated output current (i.e. 136 % overload capability) for 57 s, cycle time 300 s and 1.6 x rated output current (i.e. 160 % overload capability) for 3 s, cycle time 300 s	
– VT mode		Overload current 1.4 x rated output current (i.e. 140 % overload capability) for 3 s, and 1.1 x rated output current (i.e. 110 % overload capability) for 60 s, cycle time 300 s	
Inrush current	not higher than rated input current		
Control method	Vector control, torque control, linear V/f characteristic; quadratic V/f characteristic; Multipoint characteristic (programmable V/f characteristic); flux current control (FCC)		
Pulse frequency	0.12 kW to 75 kW 90 kW to 200 kW	4 kHz (standard); 16 kHz (standard with 230 V inverters 0.12 kW to 5.5 kW) 2 kHz to 16 kHz (in 2 kHz steps) 2 kHz (standard with VT mode); 4 kHz (standard with CT mode) 2 kHz to 4 kHz (in 2 kHz steps)	
Fixed frequencies	15, programmable		
Skip frequency ranges	4, programmable		
Setpoint resolution	0.01 Hz digital; 0.01 Hz serial; 10 bit analog		
Digital inputs	6 fully programmable isolated digital inputs; switchable PNP/NPN		
Analog inputs	2 programmable analog inputs • 0 V to 10 V, 0 mA to 20 mA and –10 V to +10 V (AIN1) • 0 V to 10 V and 0 mA to 20 mA (AIN2) • both can be used as 7th/8th digital input		
Relay outputs	3, programmable, 30 V DC/5 A (resistive load); 250 V AC/2A (inductive load)		
Analog outputs	2, programmable (0/4 mA to 20 mA)		
Serial interfaces	RS-485, optional RS-232		
Motor cable lengths	without output choke with output choke	0.12 – 75 kW: max. 50 m (shielded), max. 100 m (unshielded) 90 – 250 kW: max. 200 m (shielded), max. 300 m (unshielded) see variant dependent options	
Electromagnetic compatibility (see Selection and Ordering Data)	EMC filter, Class A or Class B to EN 55 011 available as an option Inverter with internal filter Class A available		
Braking	Resistance braking with DC braking, compound braking, integrated brake chopper (integrated brake chopper only with 0.12 kW to 75 kW inverters)		
Degree of protection	IP20		
Operating temperature (without derating)	0.12 kW to 75 kW 90 kW to 200 kW	CT: –10 °C to +50 °C (+14 °F to +122 °F) VT: –10 °C to +40 °C (+14 °F to +104 °F) 0 °C to +40 °C (+32 °F to +104 °F)	
Storage temperature	–40 °C to +70 °C (–40 °F to +158 °F)		
Relative humidity	95% (non-condensing)		
Installation altitude	0.12 kW to 75 kW 90 kW to 200 kW	up to 1000 m above sea level without derating up to 2000 m above sea level without derating	
Standard SCCR (Short Circuit Current Rating) ¹⁾	FSA, FSB, FSC: 10 kA FSD, FSE, FSF, FSFX, FSGX: 42 kA		
Protection features for	Undervoltage, overvoltage, overload, earth faults, short-circuits, stall prevention, locked motor protection, motor over-temperature, inverter overtemperature, parameter change protection		
Compliance with standards	Ⓜ, cⓂ, CE, c-tick		
CE marking	Conformity with low-voltage directive 73/23/EEC		
Cooling-air volumetric flow required, dimensions and weights (without options)	Frame size (FS)	Cooling-air volumetric flow required (l/s)/(CFM)	H x W x D, max. (mm) Weight, approx. (kg)
	A	4.8/10.2	173 x 73 x 149 1.3
	B	24/51	202 x 149 x 172 3.4
	C	54.9/116.3	245 x 185 x 195 5.7
	D	2 x 54.9/2 x 116.3	520 x 275 x 245 17
	E	2 x 54.9/2 x 116.3	650 x 275 x 245 22
	F without filter	150/317.79	850 x 350 x 320 56
	F with filter	150/317.79	1150 x 350 x 320 75
	FX	225/478.13	1400 x 326 x 356 116
	GX	440/935	1533 x 326 x 545 174

1) For footnote, see page 4/7.

CFM: Cubic Feet per Minute

Derating data

Pulse frequency

Output kW	Rated output current in A for a pulse frequency of						
	4 kHz	6 kHz	8 kHz	10 kHz	12 kHz	14 kHz	16 kHz
Mains voltage 1/3 AC 200 V							
0.12 to 5.5	Values correspond to the 4 kHz standard values. No derating, since 16 kHz standard.						
7.5	28.0	26.6	25.2	22.4	19.6	16.8	14.0
11	42.0	37.8	33.6	29.4	25.2	21.0	16.8
15	54.0	48.6	43.2	37.8	32.4	27.0	21.6
18.5	68.0	64.6	61.2	54.4	47.6	40.8	34.0
22	80.0	72.0	64.0	56.0	48.0	40.0	32.0
30	104.0	91.0	78.0	70.2	62.4	57.2	52.0
37	130.0	113.8	97.5	87.8	78.0	71.5	65.0
45	154.0	134.8	115.5	104.0	92.4	84.7	77.0
Mains operating voltage 3 AC 400 V							
0.37	1.3	1.3	1.3	1.3	1.3	1.2	1.0
0.55	1.7	1.7	1.7	1.6	1.5	1.4	1.2
0.75	2.2	2.2	2.2	2.0	1.8	1.5	1.3
1.1	3.1	2.9	2.8	2.5	2.2	1.9	1.6
1.5	4.1	3.7	3.3	2.9	2.5	2.1	1.6
2.2	5.9	5.6	5.3	4.7	4.1	3.5	3.0
3.0	7.7	6.9	6.2	5.4	4.6	3.9	3.1
4.0	10.2	9.2	8.2	7.1	6.1	5.1	4.1
5.5	13.2	11.9	10.6	9.2	7.9	6.6	5.3
7.5	19.0	18.1	17.1	15.2	13.3	11.4	9.5
11.0	26.0	23.4	20.8	18.2	15.6	13.0	10.4
15.0	32.0	30.4	28.8	25.6	22.4	19.2	16.0
18.5	38.0	34.2	30.4	26.6	22.8	19.0	15.2
22	45.0	40.5	36.0	31.5	27.0	22.5	18.0
30	62.0	58.9	55.8	49.6	43.4	37.2	31.0
37	75.0	67.5	60.0	52.5	45.0	37.5	30.0
45	90.0	76.5	63.0	51.8	40.5	33.8	27.0
55	110.0	93.5	77.0	63.3	49.5	41.3	33.0
75	145.0	112.4	79.8	68.9	58.0	50.8	43.5
90	178.0	–	–	–	–	–	–
110	205.0	–	–	–	–	–	–
132	250.0	–	–	–	–	–	–
160	302.0	–	–	–	–	–	–
200	370.0	–	–	–	–	–	–
Mains operating voltage 3 AC 500 V							
0.75	1.4	1.2	1.0	0.8	0.7	0.6	0.6
1.5	2.7	2.2	1.6	1.4	1.1	0.9	0.8
2.2	3.9	2.9	2.0	1.6	1.2	1.0	0.8
4.0	6.1	4.6	3.1	2.4	1.8	1.5	1.2
5.5	9.0	6.8	4.5	3.6	2.7	2.3	1.8
7.5	11.0	8.8	6.6	5.5	4.4	3.9	3.3
11.0	17.0	12.8	8.5	6.8	5.1	4.3	3.4
15.0	22.0	17.6	13.2	11.0	8.8	7.7	6.6
18.5	27.0	20.3	13.5	10.8	8.1	6.8	5.4
22	32.0	24.0	16.0	12.8	9.6	8.0	6.4
30	41.0	32.8	24.6	20.5	16.4	14.4	12.3
37	52.0	39.0	26.0	20.8	15.6	13.0	10.4
45	62.0	52.7	43.4	40.3	37.2	32.6	27.9
55	77.0	67.4	57.8	52.0	46.2	42.4	38.5
75	99.0	84.2	69.3	64.4	59.4	52.0	44.6

1) Applies to industrial control cabinet installations to NEC article 409/UL 508A.

For further information, visit us on the Internet at:

<http://support.automation.siemens.com/WW/view/en/23995621>

MICROMASTER 440

Technical data

Derating data (continued)

Operating temperature

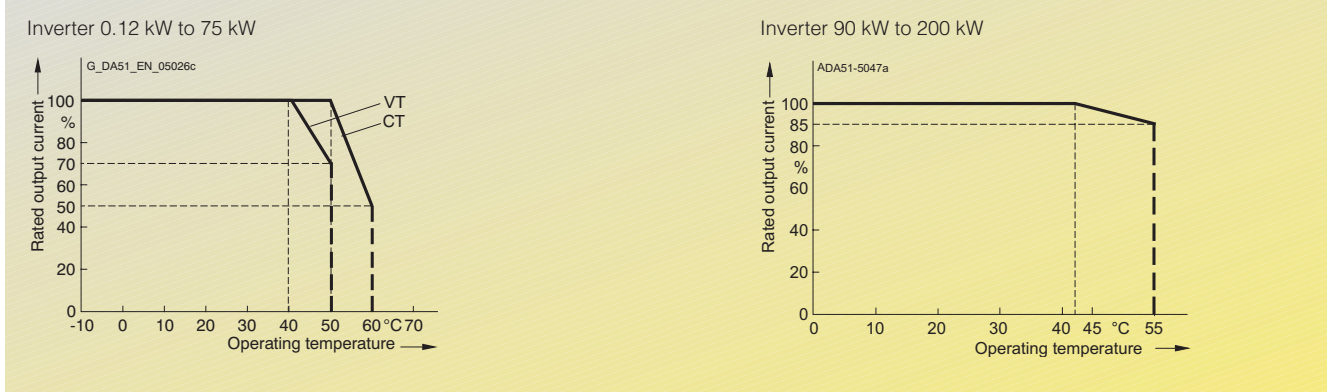

Installation altitude above sea level

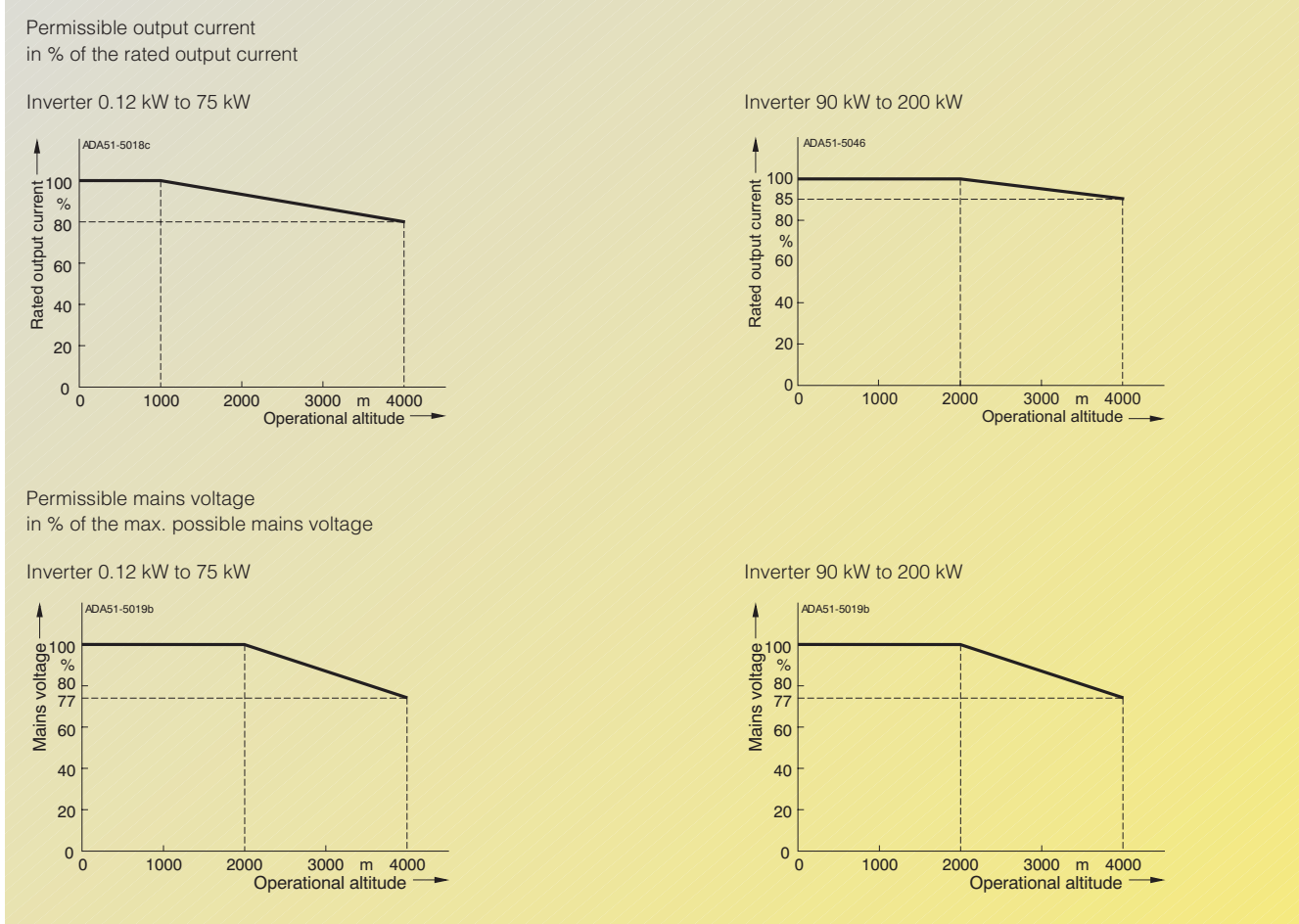

4

MICROMASTER 440 inverter without filter²⁾

CT (constant torque)				VT (variable torque)				MICROMASTER 440 without filter ²⁾		
Output		Rated input current ¹⁾	Rated output current	Output		Rated input current ¹⁾	Rated output current	Frame size	Weight, approx.	Order No.
kW	hp	A	A	kW	hp	A	A	(FS)	kg	
Mains voltage 1 AC 200 V to 240 V										
0.12	0.16	1.8	0.9	–	–	–	–	A	1.3	6SE6440-2UC11-2AA1
0.25	0.33	3.2	1.7	–	–	–	–	A	1.3	6SE6440-2UC12-5AA1
0.37	0.50	4.6	2.3	–	–	–	–	A	1.3	6SE6440-2UC13-7AA1
0.55	0.75	6.2	3.0	–	–	–	–	A	1.3	6SE6440-2UC15-5AA1
0.75	1.0	8.2	3.9	–	–	–	–	A	1.3	6SE6440-2UC17-5AA1
1.1	1.5	11.0	5.5	–	–	–	–	B	3.3	6SE6440-2UC21-1BA1
1.5	2	14.4	7.4	–	–	–	–	B	3.3	6SE6440-2UC21-5BA1
2.2	3	20.2	10.4	–	–	–	–	B	3.3	6SE6440-2UC22-2BA1
3.0	4	35.5	13.6	–	–	–	–	C	5.5	6SE6440-2UC23-0CA1
Mains operating voltage 3 AC 200 V to 240 V										
0.12	0.16	1.1	0.9	–	–	–	–	A	1.3	6SE6440-2UC11-2AA1
0.25	0.33	1.9	1.7	–	–	–	–	A	1.3	6SE6440-2UC12-5AA1
0.37	0.50	2.7	2.3	–	–	–	–	A	1.3	6SE6440-2UC13-7AA1
0.55	0.75	3.6	3.0	–	–	–	–	A	1.3	6SE6440-2UC15-5AA1
0.75	1.0	4.7	3.9	–	–	–	–	A	1.3	6SE6440-2UC17-5AA1
1.1	1.5	6.4	5.5	–	–	–	–	B	3.3	6SE6440-2UC21-1BA1
1.5	2.0	8.3	7.4	–	–	–	–	B	3.3	6SE6440-2UC21-5BA1
2.2	3.0	11.7	10.4	–	–	–	–	B	3.3	6SE6440-2UC22-2BA1
3.0	4.0	15.6	13.6	–	–	–	–	C	5.5	6SE6440-2UC23-0CA1
4.0	5.0	19.7	17.5	5.5	7.5	28.3	22	C	5.5	6SE6440-2UC24-0CA1
5.5	7.5	26.5	22	7.5	10	34.2	28	C	5.5	6SE6440-2UC25-5CA1
7.5	10	34.2	28	11.0	15	38.0	42	D	16	6SE6440-2UC27-5DA1
11.0	15	38.0	42	15.0	20	50.0	54	D	16	6SE6440-2UC31-1DA1
15.0	20	50.0	54	18.5	25	62.0	68	D	16	6SE6440-2UC31-5DA1
18.5	25	62.0	68	22	30	71.0	80	E	20	6SE6440-2UC31-8EA1
22	30	71.0	80	30	40	96.0	104	E	20	6SE6440-2UC32-2EA1
30	40	96.0	104	37	50	114.0	130	F	55	6SE6440-2UC33-0FA1
37	50	114.0	130	45	60	135.0	154	F	55	6SE6440-2UC33-7FA1
45	60	135.0	154	55	75	164.0	178	F	55	6SE6440-2UC34-5FA1
Mains operating voltage 3 AC 380 V to 480 V										
0.37	0.50	2.2	1.3	–	–	–	–	A	1.3	6SE6440-2UD13-7AA1
0.55	0.75	2.8	1.7	–	–	–	–	A	1.3	6SE6440-2UD15-5AA1
0.75	1.0	3.7	2.2	–	–	–	–	A	1.3	6SE6440-2UD17-5AA1
1.1	1.5	4.9	3.1	–	–	–	–	A	1.3	6SE6440-2UD21-1AA1
1.5	2.0	5.9	4.1	–	–	–	–	A	1.3	6SE6440-2UD21-5AA1
2.2	3.0	7.5	5.9	–	–	–	–	B	3.3	6SE6440-2UD22-2BA1
3.0	4.0	10.0	7.7	–	–	–	–	B	3.3	6SE6440-2UD23-0BA1
4.0	5.0	12.8	10.2	–	–	–	–	B	3.3	6SE6440-2UD24-0BA1
5.5	7.5	15.6	13.2	7.5	10	17.3	19	C	5.5	6SE6440-2UD25-5CA1
7.5	10	22.0	18.4	11.0	15	23.1	26	C	5.5	6SE6440-2UD27-5CA1
11.0	15	23.1	26	15.0	20	33.8	32	C	5.5	6SE6440-2UD31-1CA1
15.0	20	33.8	32	18.5	25	37.0	38	D	16	6SE6440-2UD31-5DA1
18.5	25	37.0	38	22	30	43.0	45	D	16	6SE6440-2UD31-8DA1
22	30	43.0	45	30	40	59.0	62	D	16	6SE6440-2UD32-2DA1
30	40	59.0	62	37	50	72.0	75	E	20	6SE6440-2UD33-0EA1
37	50	72.0	75	45	60	87.0	90	E	20	6SE6440-2UD33-7EA1
45	60	87.0	90	55	75	104.0	110	F	56	6SE6440-2UD34-5FA1
55	75	104.0	110	75	100	139.0	145	F	56	6SE6440-2UD35-5FA1
75	100	139.0	145	90	125	169.0	178	F	56	6SE6440-2UD37-5FA1

1) Supplementary conditions:
Input current at rated operating point, applicable at short-circuit voltage of the supply $U_{sc} = 2\%$ with reference to the inverter rated power and rated mains operating voltage of 240 V or 400 V without a line commutating choke.

2) Acc. to EMC EN 61800-3 generally suited to heavy industrial applications. For details please refer to Appendix on page A/4.

MICROMASTER 440

Selection and ordering data

MICROMASTER 440 inverter without filter³⁾ (continued)

CT (constant torque)			VT (variable torque)				MICROMASTER 440 without filter ³⁾			
Output		Rated input current	Rated output current	Output		Rated input current	Rated output current	Frame size	Weight, approx.	Order No.
kW	hp	A	A	kW	hp	A	A	(FS)	kg	
Mains operating voltage 3 AC 380 V to 480 V										
90	125	169.0 ¹⁾	178	110	150	200.0 ¹⁾	205	FX	116	6SE6440-2UD38-8FA1
110	150	200.0 ¹⁾	205	132	200	245.0 ¹⁾	250	FX	116	6SE6440-2UD41-1FA1
132	200	245.0 ¹⁾	250	160	250	297.0 ¹⁾	302	GX	174	6SE6440-2UD41-3GA1
160	250	297.0 ¹⁾	302	200	300	354.0 ¹⁾	370	GX	174	6SE6440-2UD41-6GA1
200	300	354.0 ¹⁾	370	250	350	442.0 ¹⁾	477	GX	174	6SE6440-2UD42-0GA1
Mains operating voltage 3 AC 500 V to 600 V										
0.75	1.0	2.0 ²⁾	1.4	1.5	2.0	3.2 ²⁾	2.7	C	5.5	6SE6440-2UE17-5CA1
1.5	2.0	3.7 ²⁾	2.7	2.2	3.0	4.4 ²⁾	3.9	C	5.5	6SE6440-2UE21-5CA1
2.2	3.0	5.3 ²⁾	3.9	4.0	5.0	6.9 ²⁾	6.1	C	5.5	6SE6440-2UE22-2CA1
4.0	5.0	8.1 ²⁾	6.1	5.5	7.5	9.4 ²⁾	9	C	5.5	6SE6440-2UE24-0CA1
5.5	7.5	11.1 ²⁾	9	7.5	10	12.6 ²⁾	11	C	5.5	6SE6440-2UE25-5CA1
7.5	10	14.4 ²⁾	11	11.0	15	18.1 ²⁾	17	C	5.5	6SE6440-2UE27-5CA1
11.0	15	21.5 ²⁾	17	15.0	20	24.9 ²⁾	22	C	5.5	6SE6440-2UE31-1CA1
15.0	20	24.9 ²⁾	22	18.5	25	30.0 ²⁾	27	D	16	6SE6440-2UE31-5DA1
18.5	25	30.0 ²⁾	27	22	30	35.0 ²⁾	32	D	16	6SE6440-2UE31-8DA1
22	30	35.0 ²⁾	32	30	40	48.0 ²⁾	41	D	16	6SE6440-2UE32-2DA1
30	40	48.0 ²⁾	41	37	50	58.0 ²⁾	52	E	20	6SE6440-2UE33-0EA1
37	50	58.0 ²⁾	52	45	60	69.0 ²⁾	62	E	20	6SE6440-2UE33-7EA1
45	60	69.0 ²⁾	62	55	75	83.0 ²⁾	77	F	56	6SE6440-2UE34-5FA1
55	75	83.0 ²⁾	77	75	100	113.0 ²⁾	99	F	56	6SE6440-2UE35-5FA1
75	100	113.0 ²⁾	99	90	120	138.0 ²⁾	125	F	56	6SE6440-2UE37-5FA1



See Appendix for note on ordering.

All MICROMASTER 440 inverters are supplied with a Status Display Panel (SDP). A BOP, AOP or other options have to be ordered separately (see Pages 4/16 to 4/22).

Motors for MICROMASTER 440

Catalog D 81.1 contains selection and ordering data for motors which are particularly suitable for operation with the MICROMASTER 440 inverters (see Appendix for overview).

This catalog is suitable for IEC motors. For motors according to US standards (NEMA) please refer to Catalog D 81.2 U.S./Canada (see Appendix for overview) and to: <http://www.sea.siemens.com/motors>

1) Supplementary conditions: Input current at rated operating point, applicable at short-circuit voltage of the supply $U_{sc} \geq 2.33\%$ with reference to the inverter rated power and rated mains operating voltage of 400 V.

2) Supplementary conditions: Input current at rated operating point, applicable at short-circuit voltage of the supply $U_{sc} = 2\%$ with reference to the inverter rated power and rated mains operating voltage of 500 V without a line commutating choke.

3) Acc. to EMC EN 61800-3 generally suited to heavy industrial applications. For details please refer to Appendix on page A/4.

MICROMASTER 440 inverter with internal filter Class A ²⁾

CT (constant torque)			VT (variable torque)				MICROMASTER 440 with internal filter Class A ²⁾			
Output		Rated input current ¹⁾	Rated output current	Output		Rated input current ¹⁾	Rated output current	Frame size (FS)	Weight, approx. kg	Order No.
kW	hp	A	A	kW	hp	A	A			
Mains operating voltage 1 AC 200 V to 240 V										
0.12	0.16	1.8	0.9	–	–	–	–	A	1.3	6SE6440-2AB11-2AA1
0.25	0.33	3.2	1.7	–	–	–	–	A	1.3	6SE6440-2AB12-5AA1
0.37	0.50	4.6	2.3	–	–	–	–	A	1.3	6SE6440-2AB13-7AA1
0.55	0.75	6.2	3.0	–	–	–	–	A	1.3	6SE6440-2AB15-5AA1
0.75	1.0	8.2	3.9	–	–	–	–	A	1.3	6SE6440-2AB17-5AA1
1.1	1.5	11.0	5.5	–	–	–	–	B	3.4	6SE6440-2AB21-1BA1
1.5	2	14.4	7.4	–	–	–	–	B	3.4	6SE6440-2AB21-5BA1
2.2	3	20.2	10.4	–	–	–	–	B	3.4	6SE6440-2AB22-2BA1
3.0	4	35.5	13.6	–	–	–	–	C	5.7	6SE6440-2AB23-0CA1
Mains operating voltage 3 AC 200 V to 240 V										
3.0	4.0	15.6	13.6	–	–	–	–	C	5.7	6SE6440-2AC23-0CA1
4.0	5.0	19.7	17.5	5.5	7.5	28.3	22	C	5.7	6SE6440-2AC24-0CA1
5.5	7.5	26.5	22.0	7.5	10.0	34.2	28	C	5.7	6SE6440-2AC25-5CA1
Mains operating voltage 3 AC 380 V to 480 V										
2.2	3.0	7.5	5.9	–	–	–	–	B	3.4	6SE6440-2AD22-2BA1
3.0	4.0	10.0	7.7	–	–	–	–	B	3.4	6SE6440-2AD23-0BA1
4.0	5.0	12.8	10.2	–	–	–	–	B	3.4	6SE6440-2AD24-0BA1
5.5	7.5	15.6	13.2	7.5	10	17.6	19	C	5.7	6SE6440-2AD25-5CA1
7.5	10	22.0	18.4	11.0	15	23.1	26	C	5.7	6SE6440-2AD27-5CA1
11.0	15	23.1	26	15.0	20	33.8	32	C	5.7	6SE6440-2AD31-1CA1
15.0	20	33.8	32	18.5	25	37.0	38	D	17	6SE6440-2AD31-5DA1
18.5	25	37.0	38	22	30	43.0	45	D	17	6SE6440-2AD31-8DA1
22	30	43.0	45	30	40	59.0	62	D	17	6SE6440-2AD32-2DA1
30	40	59.0	62	37	50	72.0	75	E	22	6SE6440-2AD33-0EA1
37	50	72.0	75	45	60	87.0	90	E	22	6SE6440-2AD33-7EA1
45	60	87.0	90	55	75	104.0	110	F	75	6SE6440-2AD34-5FA1
55	75	104.0	110	75	100	139.0	145	F	75	6SE6440-2AD35-5FA1
75	100	139.0	145	90	125	169.0	178	F	75	6SE6440-2AD37-5FA1



See Appendix for note on ordering.

All MICROMASTER 440 inverters are supplied with a Status Display Panel (SDP). A BOP, AOP or other options have to be ordered separately (see Pages 4/16 to 4/22).

Motors for MICROMASTER 440

Catalog D 81.1 contains selection and ordering data for motors which are particularly suitable for operation with the MICROMASTER 440 inverters (see Appendix for overview).

This catalog is suitable for IEC motors. For motors according to US standards (NEMA) please refer to Catalog D 81.2 U.S./Canada (see Appendix for overview) and to: <http://www.sea.siemens.com/motors>

1) Supplementary conditions:
Input current at rated operating point, applicable at short-circuit voltage of the supply $U_{sc} = 2\%$ with reference to the inverter rated power and rated mains operating voltage of 240 V or 400 V without a line commutating choke.

2) Use of MICROMASTER inverters with internal filter is not permissible on non-grounded mains supplies.

MICROMASTER 440

Options Variant dependent options

Overview

EMC filter, Class A

Filter for inverters without an internal filter for

- 3 AC 200 V to 240 V, frame sizes A and B
- 3 AC 380 V to 480 V, frame size A, FX, GX

Filters for frame sizes FX and GX are only permitted to be used in combination with a line commutating choke.

All other inverters with the exception of inverters for 500 V to 600 V can be supplied with an internal Class A filter.

The requirements are fulfilled using shielded cables with a max. length of 25 m.

EMC filter, Class B

Filter for inverters without an internal filter for

- 3 AC 200 V to 240 V, frame sizes A and B
- 3 AC 380 V to 480 V, frame size A.

The requirements are fulfilled using shielded cables with a max. length of 25 m.

For inverters 15 kW to 75 kW without filters, EMC filters of Class B from Schaffner can be used.

The requirements are fulfilled using shielded cables with a max. length of 25 m to 50 m (depending on the type, details on request).

With this filter, the inverter complies with the emission standard EN 55 011, Class B for conducted interference emissions.

Additional EMC filter, Class B

Available for inverters with an internal Class A EMC filter, frame sizes A, B and C.

The requirements are fulfilled using shielded cables with a max. length of 25 m.

With this filter, the inverter complies with the emission standard EN 55 011, Class B for conducted interference emissions.

Filter Class B with low leakage currents

EMC filter for 1 AC 200 V to 240 V inverters, frame sizes A and B, without an internal EMC filter Class A.

With this filter, the inverter complies with the emission standard EN 55 011, Class B for conducted interference emissions. The leakage currents are reduced to < 3.5 mA.

The requirements are fulfilled using shielded cables with a max. length of 5 m.

Leakage currents:

The leakage currents of the inverters with/without filter (internal/external) may exceed 30 mA. Typical values in practice are between 10 mA and 50 mA. The exact values depend on the design, environment and cable lengths. Interference-free operation with residual current operated devices with a trigger value of 30 mA cannot be guaranteed. However, operation with residual current circuit-breakers with a trigger value of 300 mA is possible. Please refer to the Instruction Manual for details.

LC filter and sinusoidal filter

The LC filter/sinusoidal filter limits the rate of rise of voltage and the capacitive charge/discharge currents which usually occur with inverter operation. This means that much longer shielded motor cables are possible when using LC filters/sinusoidal filters and the service life of the motor achieves values similar to those with direct mains operation. Use of an output choke isn't required with that.

Please note when using LC filters/sinusoidal filters:

- Only V/f, FCC control permissible
- Please observe the derating of 15 % when selecting the appropriate inverter
- Operation only permissible with 4 kHz pulse frequency
Note: Please observe derating for frame sizes FX and GX.
- The output frequency is limited to 150 Hz
- Operation and commissioning only with connected motor as the LC filter/sinusoidal filter is not idling-proof!

The LC filters/sinusoidal filters can be used for all MICROMASTER 440 inverters of frame sizes A to GX.

- Frame sizes D to F:
The LC filters, frame sizes D to F, are designed for mounting upright in the control cabinet. Due to leakage flux lines caused by physical sources, a minimum distance of 50 mm to adjacent modules and metal parts is recommended.
- Frame sizes FX and GX:
The sinusoidal filters, frame sizes FX and GX, are designed for mounting upright in the control cabinet. Due to leakage flux lines caused by physical sources, a minimum distance of 100 mm to adjacent modules and metal parts is recommended.

Technical data

LC filter and sinusoidal filter

Mains voltage	3 AC 380 V to 480 V	3 AC 500 V to 600 V
Current (at 40 °C/50 °C)		
For frame size A (0.37 to 1.5 kW)	4.5 A/4.1 A	–
For frame size B (2.2 to 4 kW)	11.2 A/10.2 A	–
For frame size C (0.75 to 4 kW)	–	9.0 A/6.1 A
For frame size C (5.5 to 11 kW)	32.6 A/26 A	22.4 A/17 A
For frame size D (15 kW)	38.8 A/32 A	27.5 A/22 A
For frame size D (18.5 kW)	45.9 A/38 A	32.6 A/27 A
For frame size D (22 kW)	63.2 A/45 A	41.8 A/32 A
For frame size E (30 kW)	76.5 A/62 A	53 A/41 A
For frame size E (37 kW)	112.2 A/90 A	63.2 A/52 A
For frame size F (45 kW)	112.2 A/90 A	78.5 A/62 A
For frame size F (55 kW)	147.9 A/110 A	101 A/77 A
For frame size F (75 kW)	181.6 A/145 A	127.5 A/99 A
Current (at 40 °C/55 °C)		
For frame size FX (90 kW and 110 kW)	225 A/191 A	–
For frame size GX (132 kW)	276 A/235 A	–
For frame size GX (160 kW)	333 A/283 A	–
For frame size GX (200 kW)	408 A/347 A	–

Technical data (continued)

LC filter and sinusoidal filter

Limiting of motor overvoltage		≤ 1078 V	
dV/dt limiting		≤ 500 V/μs	
Pulse frequency		4 kHz	
Max. motor frequency		150 Hz	
Max. permissible motor cable lengths			
For frame sizes A to F	shielded	200 m	
	unshielded	300 m	
For frame sizes FX and GX	shielded	300 m	
	unshielded	450 m	
Insulation strength		Overvoltage category III to VDE 0110	
Electromagnetic compatibility		Up to 200 m motor cable length with emissions to Class A according to EN 55 011 in conjunction with filtered inverters and unshielded cables	
For frame sizes A to F		Up to 150 m motor cable length with emissions to Class A according to EN 55 011 in conjunction with filtered inverters and unshielded cables	
For frame sizes FX and GX			
Conformity		CE according to the low-voltage directive 73/23/EEC	
Approvals		cUL E 219022	
Strain resistance		EN 60 068-2-31	
Humidity		95 % humidity, non-condensing	
Degree of protection		IP20 (to EN 60 529)	
For frame sizes A to C		IP00/IP20 (to EN 60 529 with terminal covers)	
For frame sizes D to F		IP00	
For frame sizes FX and GX			
Insulation class		H (180 °C)	
Temperature range			
For frame sizes A to F	Operation	-10 °C to +40 °C (+14 °F to +104 °F) to +50 °C (to +122 °F)	100 % P _n 80 % P _n
	Storage	-25 °C to +70 °C (-13 °F to +158 °F)	
For frame sizes FX and GX	Operation	-10 °C to +40 °C (+14 °F to +104 °F) to +55 °C (to +131 °F)	100 % P _n 85 % P _n
	Storage	-40 °C to +70 °C (-40 °F to +158 °F)	
Installation altitude			
For frame sizes A to C		Up to 2000 m:	100 % P _n
		2000 to 4000 m:	62.5 % P _n
For frame sizes D to F		Up to 1000 m:	100 % P _n
		1000 to 4000 m:	12.5 % derating for each 1000 m
For frame sizes FX and GX		Up to 2000 m:	100 % P _n
		2000 to 4000 m:	7.5 % derating for each 1000 m
Mounting position		Footprint or suspended upright	
For frame sizes A to C			
For frame sizes D to F, FX and GX			
Ventilation clearances			
For frame sizes A to C	Top	100 mm	
	Bottom	100 mm	
	Side	100 mm	
For frame sizes D to F, FX and GX	Top	100 mm	
	Side	100 mm	
Connection system	Input, litz wire or terminal	1U1, 1V1, 1W1	
	Output, terminals	1U2, 1V2, 1W2	
Torque for conductor connections		Terminal cross-section	Torque
For frame sizes A to C		-	1.5 Nm to 1.8 Nm
For frame sizes D to F		16 mm ²	2.0 Nm to 4.0 Nm
		35 mm ²	2.5 Nm to 5.0 Nm
		50 mm ²	3.0 Nm to 6.0 Nm
		95 mm ²	6.0 Nm to 12.0 Nm
		150 mm ²	10.0 Nm to 20.0 Nm
For frame sizes FX and GX		-	14.0 Nm to 31.0 Nm
Weight, approx.			
For frame size A		7 kg	
For frame size B		11 kg	
For frame size C		8.5 kg to 29 kg	
For frame size D		21 kg to 42 kg	
For frame size E		49.5 kg to 67 kg	
For frame size F		67 kg to 126 kg	
For frame size FX		135 kg	
For frame size GX		138 kg to 208 kg	

MICROMASTER 440

Options

Variant dependent options

Overview

Line commutating choke

Line commutating chokes are used to smooth voltage peaks or to bridge commutating dips. In addition, line commutating chokes reduce the effects of harmonics on the inverter and the power supply. If the line impedance is $< 1\%$, a line commutating choke must be used in order to reduce the current peaks.

In line with EN 61 000-3-2 regulations "Limits for harmonic currents with device input current ≤ 16 A per phase", there are special aspects for drives with 250 W to 550 W and 230 V single-phase supplies which can be used in non-industrial applications (1st environment).

For devices with 250 W and 350 W, it is necessary either to fit the recommended input chokes or to apply to the power utility company for authorization to connect the devices to the public power supply.

No limits are currently defined in the EN 61 000-3-2 standard for professionally used devices with a connected load > 1 kW which means that the inverters with an output power ≥ 0.75 kW comply with the EN 61 000-3-2 standard.

However, in accordance with the regulations of EN 61000-3-12 "Limits for harmonic currents > 16 A and ≤ 75 A per phase" an approval is necessary from the power supplier for drives that are intended to be connected to the public low-voltage network. Please refer to the Operating Instructions for the values of the harmonic currents.

Output choke

Output chokes can be supplied for reducing the capacitive compensation currents and dV/dt in the case of motor cables > 50 m (shielded) or > 100 m (unshielded).

For max. permissible cable lengths, see the Technical Data.

Brake resistors

The brake resistors are designed for use with the MICROMASTER 440 inverter series, frame sizes A to F, with internal brake chopper and enable loads with a large moment of inertia to be braked quickly. During braking of the motor and the load, excess energy is fed back to the inverter. This causes the voltage to rise in the DC link. The inverter transfers the excess energy to the externally mounted braking resistor.

For MICROMASTER 440 inverters of frame sizes FX and GX, external SIMOVERT MASTERDRIVES brake units and the appropriate brake resistors can be used (see Catalog DA 65.10).

Gland plate

Gland plates are available for inverters of frame sizes A, B and C. All the other frame sizes have the shield connection for the control cable integrated in the inverter.

The shield for the power cable has to be connected externally (e.g. in the control cabinet). Exception: Inverters of frame sizes D and E and frame size F with integrated class A filter. In this case the shield connection is integrated in the inverter.

The gland plate enables the shields of the power and control cables to be terminated ensuring optimum EMC performance.

Technical data

Max. permissible cable lengths from the motor to the inverter when using output chokes

The following table shows the maximum permissible cable lengths from the motor to the inverter when using output chokes.

Note:

Operation up to 150 Hz output frequency only!

Frame size (FS)	Output choke Type	Max. permissible motor cable lengths (shielded/unshielded) for a mains voltage of			
		200 V to 240 V $\pm 10\%$	380 V to 400 V $\pm 10\%$	401 V to 480 V $\pm 10\%$	500 V to 600 V $\pm 10\%$
A	6SE6400-3TC00-4AD3	200 m/300 m	–	–	–
A	6SE6400-3TC00-4AD2	–	150 m/225 m	100 m/150 m	–
B	6SE6400-3TC01-0BD3	200 m/300 m	150 m/225 m	100 m/150 m	–
C	6SE6400-3TC03-2CD3	200 m/300 m	200 m/300 m	100 m/150 m	–
C	6SE6400-3TC01-8CE3	–	–	–	100 m/150 m
D to F	6SE6400-3TC.	200 m/300 m	200 m/300 m	200 m/300 m	200 m/300 m
FX	6SL3000-2BE32-1AA0	–	300 m/450 m	300 m/450 m	–
FX	6SL3000-2BE32-6AA0	–	300 m/450 m	300 m/450 m	–
GX	6SL3000-2BE33-2AA0	–	300 m/450 m	300 m/450 m	–
GX	6SL3000-2BE33-8AA0	–	300 m/450 m	300 m/450 m	–
GX	6SL3000-2BE35-0AA0	–	300 m/450 m	300 m/450 m	–

Options Variant dependent options

Design

General installation instructions

- A maximum of two footprint components plus inverter are permissible.
- If an LC filter is used, it must, if possible, be mounted directly on the wall of the control cabinet due to weight reasons. If an LC filter of frame size C is used, therefore, only one footprint component is permissible. If a line choke and LC filter are used, the line choke must be located on the left of the inverter. Required distance between line choke and inverter: 75 mm.
- The EMC filter must be mounted directly below the frequency inverter if possible.
- If mounted on the side, the line-side components are to be mounted to the left of the frequency inverter whereas the output-side components are to be mounted to the right of the frequency inverter.
- If a braking resistor is used, it must, if possible, be mounted directly on the wall of the control cabinet due to reasons relating to temperature increases.

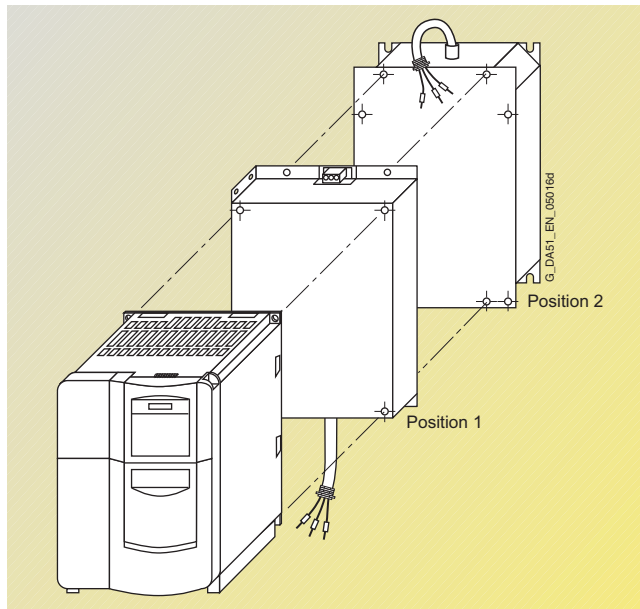

Example of installation with frequency inverter, EMC filter (position 1) and line choke (position 2)

Availability of the options as footprint components

	Frame size									
	A	B	C	D	E	F	G	FX	GX	
Line commutating choke	✓	✓	✓	✓	✓					
EMC filter	✓	✓	✓							
LC filter	✓	✓	✓							
Output choke	✓	✓	✓							
Braking resistor	✓	✓								

Recommended combinations of inverters and options

Frequency inverter Frame size	Footprint		Mounted on side	
	Position 1	Position 2	To the left of the inverter (for line-side components)	To the right of the inverter (for output-side components)
A and B	EMC filter	Line commutating choke	–	Output choke <u>and/or</u> Braking resistor
	EMC filter <u>or</u> Line commutating choke	Output choke <u>or</u> LC filter	–	Braking resistor
	EMC filter <u>or</u> Line commutating choke	Braking resistor	–	–
	EMC filter <u>or</u> Line commutating choke <u>or</u> Braking resistor	–	–	–
C	EMC filter	Line commutating choke	–	Output choke <u>and/or</u> Braking resistor
	EMC filter <u>or</u> Line commutating choke	Output choke	–	Braking resistor
	LC filter	–	EMC filter <u>and/or</u> Line commutating choke	Braking resistor
D and E	Line commutating choke	–	EMC filter	Output choke <u>or</u> LC filter <u>and/or</u> Braking resistor
F, G, FX and GX	–	–	EMC filter <u>and/or</u> Line commutating choke	Output choke <u>or</u> LC filter <u>and/or</u> Braking resistor

MICROMASTER 440

Options

Variant dependent options

Selection and ordering data

The options listed here (filters, chokes, brake resistors, gland plates, fuses and circuit-breakers) must be selected to match the respective inverter.

The inverter and the associated options have the same voltage ratings. Alternatively fuses and circuit-breakers can be provided. Both provide short



circuit protection of the inverter supply line and the inverter. A semiconductor protection of the inverter with the suggested 3NA... fuses and the

3RV.../3VL... circuit-breakers is not envisaged.

*) Must be used in combination with a line commutating choke.

Mains voltage	Output (CT)		Inverter without filter	Order No. of the options		
	kW	hp		EMC filter, Class A	EMC filter, Class B	Line commutating choke
1 AC 200 V to 240 V	0.12	0.16	6SE6440-2UC11-2AA1	–	6SE6400-2FL01-0AB0	6SE6400-3CC00-4AB3
	0.25	0.33	6SE6440-2UC12-5AA1	–	with low leakage currents	
	0.37	0.50	6SE6440-2UC13-7AA1	–		6SE6400-3CC01-0AB3
	0.55	0.75	6SE6440-2UC15-5AA1	–		
	0.75	1.0	6SE6440-2UC17-5AA1	–		
	1.1	1.5	6SE6440-2UC21-1BA1	–	6SE6400-2FL02-6BB0	6SE6400-3CC02-6BB3
	1.5	2.0	6SE6440-2UC21-5BA1	–	with low leakage currents	
	2.2	3.0	6SE6440-2UC22-2BA1	–		
	3.0	4.0	6SE6440-2UC23-0CA1	–	–	6SE6400-3CC03-5CB3
	3 AC 200 V to 240 V	0.12	0.16	6SE6440-2UC11-2AA1	6SE6400-2FA00-6AD0	6SE6400-2FB00-6AD0
0.25		0.33	6SE6440-2UC12-5AA1			
0.37		0.50	6SE6440-2UC13-7AA1			6SE6400-3CC00-5AC3
0.55		0.75	6SE6440-2UC15-5AA1			
0.75		1.0	6SE6440-2UC17-5AA1			
1.1		1.5	6SE6440-2UC21-1BA1	6SE6400-2FA01-4BC0	6SE6400-2FB01-4BC0	6SE6400-3CC00-8BC3
1.5		2.0	6SE6440-2UC21-5BA1			6SE6400-3CC01-4BD3
2.2		3.0	6SE6440-2UC22-2BA1			
3.0		4.0	6SE6440-2UC23-0CA1	–	–	6SE6400-3CC01-7CC3
4.0		5.0	6SE6440-2UC24-0CA1	–	–	6SE6400-3CC03-5CD3
5.5		7.5	6SE6440-2UC25-5CA1	–	–	
7.5		10	6SE6440-2UC27-5DA1	–	–	6SE6400-3CC05-2DD0
11.0		15	6SE6440-2UC31-1DA1	–	–	
15.0		20	6SE6440-2UC31-5DA1	–	–	
18.5		25	6SE6440-2UC31-8EA1	–	–	6SE6400-3CC08-8EC0
22		30	6SE6440-2UC32-2EA1	–	–	
30		40	6SE6440-2UC33-0FA1	–	–	6SE6400-3CC11-7FD0
37		50	6SE6440-2UC33-7FA1	–	–	
45		60	6SE6440-2UC34-5FA1	–	–	
3 AC 380 V to 480 V	0.37	0.50	6SE6440-2UD13-7AA1	6SE6400-2FA00-6AD0	6SE6400-2FB00-6AD0	6SE6400-3CC00-2AD3
	0.55	0.75	6SE6440-2UD15-5AA1			
	0.75	1.0	6SE6440-2UD17-5AA1			6SE6400-3CC00-4AD3
	1.1	1.5	6SE6440-2UD21-1AA1			
	1.5	2.0	6SE6440-2UD21-5AA1			6SE6400-3CC00-6AD3
	2.2	3.0	6SE6440-2UD22-2BA1	–	–	6SE6400-3CC01-0BD3
	3.0	4.0	6SE6440-2UD23-0BA1	–	–	
	4.0	5.0	6SE6440-2UD24-0BA1	–	–	6SE6400-3CC01-4BD3
	5.5	7.5	6SE6440-2UD25-5CA1	–	–	6SE6400-3CC02-2CD3
	7.5	10	6SE6440-2UD27-5CA1	–	–	
	11.0	15	6SE6440-2UD31-1CA1	–	–	6SE6400-3CC03-5CD3
	15.0	20	6SE6440-2UD31-5DA1	–	–	6SE6400-3CC04-4DD0
	18.5	25	6SE6440-2UD31-8DA1	–	–	
	22	30	6SE6440-2UD32-2DA1	–	EMC filter, Class B, available from Schaffner	6SE6400-3CC05-2DD0
	30	40	6SE6440-2UD33-0EA1	–		6SE6400-3CC08-3ED0
	37	50	6SE6440-2UD33-7EA1	–		
	45	60	6SE6440-2UD34-5FA1	–		6SE6400-3CC11-2FD0
	55	75	6SE6440-2UD35-5FA1	–		
	75	100	6SE6440-2UD37-5FA1	–		6SE6400-3CC11-7FD0
	90	125	6SE6440-2UD38-8FA1	6SL3000-0BE32-5AA0 *)	–	6SL3000-0CE32-3AA0
110	150	6SE6440-2UD41-1FA1	6SL3000-0BE34-4AA0 *)	–	6SL3000-0CE32-8AA0	
132	200	6SE6440-2UD41-3GA1	–	–	6SL3000-0CE33-3AA0	
160	250	6SE6440-2UD41-6GA1	–	–	6SL3000-0CE35-1AA0	
200	300	6SE6440-2UD42-0GA1	6SL3000-0BE36-0AA0 *)	–		
3 AC 500 V to 600 V	0.75	1.0	6SE6440-2UE17-5CA1	–	–	6SE6400-3CC00-4CE3
	1.5	2.0	6SE6440-2UE21-5CA1	–	–	
	2.2	3.0	6SE6440-2UE22-2CA1	–	–	6SE6400-3CC00-8CE3
	4.0	5.0	6SE6440-2UE24-0CA1	–	–	
	5.5	7.5	6SE6440-2UE25-5CA1	–	–	6SE6400-3CC02-4CE3
	7.5	10	6SE6440-2UE27-5CA1	–	–	
	11.0	15	6SE6440-2UE31-1CA1	–	–	
	15.0	20	6SE6440-2UE31-5DA1	–	–	6SE6400-3CC04-4DD0
	18.5	25	6SE6440-2UE31-8DA1	–	–	
	22	30	6SE6440-2UE32-2DA1	–	–	
	30	40	6SE6440-2UE33-0EA1	–	–	6SE6400-3CC08-3ED0
	37	50	6SE6440-2UE33-7EA1	–	–	
	45	60	6SE6440-2UE34-5FA1	–	–	6SE6400-3CC11-2FD0
55	75	6SE6440-2UE35-5FA1	–	–		
75	100	6SE6440-2UE37-5FA1	–	–		

Selection and ordering data (continued)

All options are certified to , except fuses. The 3NE1 fuses are -listed (equivalent to ).

Additional information on the listed fuses and circuit-breakers can be found in Catalogs LV 1 and LV 1 T.

Mains voltage	Output (CT)		Inverter without filter	Order No. of the options LC/sinusoidal filter	Output choke	Brake resistors
	kW	hp				
1 AC 200 V to 240 V	0.12	0.16	6SE6440-2UC11-2AA1	–	6SE6400-3TC00-4AD3	6SE6400-4BC05-0AA0
	0.25	0.33	6SE6440-2UC12-5AA1	–		
	0.37	0.50	6SE6440-2UC13-7AA1	–		
	0.55	0.75	6SE6440-2UC15-5AA1	–		
	0.75	1.0	6SE6440-2UC17-5AA1	–		
	1.1	1.5	6SE6440-2UC21-1BA1	–	6SE6400-3TC01-0BD3	6SE6400-4BC11-2BA0
	1.5	2.0	6SE6440-2UC21-5BA1	–		
	2.2	3.0	6SE6440-2UC22-2BA1	–		
	3.0	4.0	6SE6440-2UC23-0CA1	–	6SE6400-3TC03-2CD3	6SE6400-4BC12-5CA0
3 AC 200 V to 240 V	0.12	0.16	6SE6440-2UC11-2AA1	–	6SE6400-3TC00-4AD3	6SE6400-4BC05-0AA0
	0.25	0.33	6SE6440-2UC12-5AA1	–		
	0.37	0.50	6SE6440-2UC13-7AA1	–		
	0.55	0.75	6SE6440-2UC15-5AA1	–		
	0.75	1.0	6SE6440-2UC17-5AA1	–		
	1.1	1.5	6SE6440-2UC21-1BA1	–	6SE6400-3TC01-0BD3	6SE6400-4BC11-2BA0
	1.5	2.0	6SE6440-2UC21-5BA1	–		
	2.2	3.0	6SE6440-2UC22-2BA1	–		
	3.0	4.0	6SE6440-2UC23-0CA1	–	6SE6400-3TC03-2CD3	6SE6400-4BC12-5CA0
	4.0	5.0	6SE6440-2UC24-0CA1	–		6SE6400-4BC13-0CA0
	5.5	7.5	6SE6440-2UC25-5CA1	–		
	7.5	10	6SE6440-2UC27-5DA1	–	6SE6400-3TC05-4DD0	6SE6400-4BC18-0DA0
	11.0	15	6SE6440-2UC31-1DA1	–		
	15.0	20	6SE6440-2UC31-5DA1	–		
	18.5	25	6SE6440-2UC31-8EA1	–	6SE6400-3TC08-0ED0	6SE6400-4BC21-2EA0
	22	30	6SE6440-2UC32-2EA1	–		
	30	40	6SE6440-2UC33-0FA1	–	6SE6400-3TC15-4FD0	6SE6400-4BC22-5FA0
37	50	6SE6440-2UC33-7FA1	–			
45	60	6SE6440-2UC34-5FA1	–			
3 AC 380 V to 480 V	0.37	0.50	6SE6440-2UD13-7AA1	6SE6400-3TD00-4AD0	6SE6400-3TC00-4AD2	6SE6400-4BD11-0AA0
	0.55	0.75	6SE6440-2UD15-5AA1			
	0.75	1.0	6SE6440-2UD17-5AA1			
	1.1	1.5	6SE6440-2UD21-1AA1			
	1.5	2.0	6SE6440-2UD21-5AA1			
	2.2	3.0	6SE6440-2UD22-2BA1	6SE6400-3TD01-0BD0	6SE6400-3TC01-0BD3	6SE6400-4BD12-0BA0
	3.0	4.0	6SE6440-2UD23-0BA1			
	4.0	5.0	6SE6440-2UD24-0BA1			
	5.5	7.5	6SE6440-2UD25-5CA1	6SE6400-3TD03-2CD0	6SE6400-3TC03-2CD3	6SE6400-4BD16-5CA0
	7.5	10	6SE6440-2UD27-5CA1			
	11.0	15	6SE6440-2UD31-1CA1			
	15.0	20	6SE6440-2UD31-5DA1	6SE6400-3TD03-7DD0	6SE6400-3TC05-4DD0	6SE6400-4BD21-2DA0
	18.5	25	6SE6440-2UD31-8DA1	6SE6400-3TD04-8DD0	6SE6400-3TC03-8DD0	
	22	30	6SE6440-2UD32-2DA1	6SE6400-3TD06-1DD0	6SE6400-3TC05-4DD0	
	30	40	6SE6440-2UD33-0EA1	6SE6400-3TD07-2ED0	6SE6400-3TC08-0ED0	6SE6400-4BD22-2EA0
	37	50	6SE6440-2UD33-7EA1	6SE6400-3TD11-5FD0	6SE6400-3TC07-5ED0	
	45	60	6SE6440-2UD34-5FA1		6SE6400-3TC14-5FD0	6SE6400-4BD24-0FA0
	55	75	6SE6440-2UD35-5FA1	6SE6400-3TD15-0FD0	6SE6400-3TC15-4FD0	
	75	100	6SE6440-2UD37-5FA1	6SE6400-3TD18-0FD0	6SE6400-3TC14-5FD0	
	90	125	6SE6440-2UD38-8FA1	6SL3000-2CE32-3AA0	6SL3000-2BE32-1AA0	–
110	150	6SE6440-2UD41-1FA1		6SL3000-2BE32-6AA0	–	
132	200	6SE6440-2UD41-3GA1	6SL3000-2CE32-8AA0	6SL3000-2BE33-2AA0	–	
160	250	6SE6440-2UD41-6GA1	6SL3000-2CE33-3AA0	6SL3000-2BE33-8AA0	–	
200	300	6SE6440-2UD42-0GA1	6SL3000-2CE34-1AA0	6SL3000-2BE35-0AA0	–	
3 AC 500 V to 600 V	0.75	1.0	6SE6440-2UE17-5CA1	6SE6400-3TD01-0CE0	6SE6400-3TC01-8CE3	6SE6400-4BE14-5CA0
	1.5	2.0	6SE6440-2UE21-5CA1			
	2.2	3.0	6SE6440-2UE22-2CA1			
	4.0	5.0	6SE6440-2UE24-0CA1			
	5.5	7.5	6SE6440-2UE25-5CA1	6SE6400-3TD02-3CE0		
	7.5	10	6SE6440-2UE27-5CA1			6SE6400-4BE16-5CA0
	11.0	15	6SE6440-2UE31-1CA1			
	15.0	20	6SE6440-2UE31-5DA1	6SE6400-3TD02-3DE0	6SE6400-3TC03-2DE0	6SE6400-4BE21-3DA0
	18.5	25	6SE6440-2UE31-8DA1	6SE6400-3TD03-2DE0		
	22	30	6SE6440-2UE32-2DA1	6SE6400-3TD03-7DE0		
	30	40	6SE6440-2UE33-0EA1	6SE6400-3TD04-8EE0	6SE6400-3TC06-2FE0	6SE6400-4BE21-8EA0
	37	50	6SE6440-2UE33-7EA1	6SE6400-3TD06-1EE0		
	45	60	6SE6440-2UE34-5FA1	6SE6400-3TD07-1FE0		6SE6400-4BE24-2FA0
	55	75	6SE6440-2UE35-5FA1	6SE6400-3TD10-0FE0	6SE6400-3TC08-8FE0	
	75	100	6SE6440-2UE37-5FA1	6SE6400-3TD11-5FE0		

MICROMASTER 440

Options
Variant dependent options

Selection and ordering data (continued)

● Use in America requires Ⓜ-listed fuses such as the Class NON/NOS range from Bussmann.

Mains voltage	Output (CT)		Inverter without filter	Order No. of options Gland plate	Fuses (see LV 1)		Circuit-breaker (see Catalog LV 1)			
	kW	hp			3NA3	3NE1 (Ⓜ)				
1 AC 200 V to 240 V	0.12	0.16	6SE6440-2UC11-2AA1	6SE6400-0GP00-0AA0	3NA3803	●	3RV1021-1EA10			
	0.25	0.33	6SE6440-2UC12-5AA1				3RV1021-1HA10			
	0.37	0.50	6SE6440-2UC13-7AA1				3RV1021-1JA10			
	0.55	0.75	6SE6440-2UC15-5AA1	6SE6400-0GP00-0BA0	3NA3805	3RV1021-1KA10	3RV1021-4AA10			
	0.75	1.0	6SE6440-2UC17-5AA1				3RV1021-4DA10			
	1.1	1.5	6SE6440-2UC21-1BA1	6SE6400-0GP00-0CA0	3NA3807	3RV1021-1KA10	3RV1021-4EA10			
	1.5	2.0	6SE6440-2UC21-5BA1				3RV1031-4EA10			
	2.2	3.0	6SE6440-2UC22-2BA1				3RV1031-4FA10			
	3.0	4.0	6SE6440-2UC23-0CA1	6SE6400-0GP00-0CA0	3NA3817	3RV1041-4JA10	3RV1041-4JA10			
	3 AC 200 V to 240 V	0.12	0.16				6SE6440-2UC11-2AA1	6SE6400-0GP00-0AA0	3NA3803	●
0.25		0.33	6SE6440-2UC12-5AA1				3RV1021-1DA10			
0.37		0.50	6SE6440-2UC13-7AA1				3RV1021-1FA10			
0.55		0.75	6SE6440-2UC15-5AA1				6SE6400-0GP00-0BA0	3NA3805	3RV1021-1GA10	3RV1021-1HA10
0.75		1.0	6SE6440-2UC17-5AA1							3RV1021-1KA10
1.1		1.5	6SE6440-2UC21-1BA1				6SE6400-0GP00-0CA0	3NA3807	3RV1021-1KA10	3RV1021-4AA10
1.5		2.0	6SE6440-2UC21-5BA1							3RV1021-4CA10
2.2		3.0	6SE6440-2UC22-2BA1							3RV1021-4FA10
3.0		4.0	6SE6440-2UC23-0CA1				6SE6400-0GP00-0CA0	3NA3810	3RV1031-4EA10	3RV1031-4EA10
4.0		5.0	6SE6440-2UC24-0CA1	3RV1031-4FA10						
5.5	7.5	6SE6440-2UC25-5CA1	3RV1031-4HA10							
7.5	10	6SE6440-2UC27-5DA1	3RV1042-4JA10							
11.0	15	6SE6440-2UC31-1DA1	3RV1042-4LA10							
15.0	20	6SE6440-2UC31-5DA1	3VL1712-.DD33-....							
18.5	25	6SE6440-2UC31-8EA1	3NA3820	3NE1817-0	3RV1042-4KA10					
22	30	6SE6440-2UC32-2EA1	3NA3822	3NE1820-0	3RV1042-4MA10					
30	40	6SE6440-2UC33-0FA1	3NA3824	3NE1225-0	3VL3725-.DC36-....					
37	50	6SE6440-2UC33-7FA1	3NA3830	3NE1021-0	3VL4731-.DC36-....					
45	60	6SE6440-2UC34-5FA1	3NA3832	3NE1022-0	3VL1716-.DD33-....					
3 AC 380 V to 480 V	0.37	0.50	6SE6440-2UD13-7AA1	6SE6400-0GP00-0AA0	3NA3803	●	3RV1021-1CA10			
	0.55	0.75	6SE6440-2UD15-5AA1				3RV1021-1DA10			
	0.75	1.0	6SE6440-2UD17-5AA1				3RV1021-1FA10			
	1.1	1.5	6SE6440-2UD21-1AA1	6SE6400-0GP00-0BA0	3NA3805	3RV1021-1GA10	3RV1021-1JA10			
	1.5	2.0	6SE6440-2UD21-5AA1				3RV1021-1KA10			
	2.2	3.0	6SE6440-2UD22-2BA1	6SE6400-0GP00-0CA0	3NA3807	3RV1021-1KA10	3RV1021-4AA10			
	3.0	4.0	6SE6440-2UD23-0BA1				3RV1021-4BA10			
	4.0	5.0	6SE6440-2UD24-0BA1				3RV1031-4EA10			
	5.5	7.5	6SE6440-2UD25-5CA1	6SE6400-0GP00-0CA0	3NA3812	3RV1031-4FA10	3RV1031-4FA10			
	7.5	10	6SE6440-2UD27-5CA1				3RV1031-4HA10			
	11.0	15	6SE6440-2UD31-1CA1				3RV1042-4KA10			
	15.0	20	6SE6440-2UD31-5DA1				3NA3820	3NE1817-0	3RV1042-4KA10	
	18.5	25	6SE6440-2UD31-8DA1				3NA3822	3NE1818-0	3RV1042-4MA10	
	22	30	6SE6440-2UD32-2DA1				3NA3824	3NE1820-0	3VL1712-.DD33-....	
	30	40	6SE6440-2UD33-0EA1				3NA3830	3NE1021-0	3VL1716-.DD33-....	
	37	50	6SE6440-2UD33-7EA1				3NA3832	3NE1022-0	3VL3720-.DC36-....	
	45	60	6SE6440-2UD34-5FA1				3NA3836	3NE1224-0	3VL3725-.DC36-....	
	55	75	6SE6440-2UD35-5FA1				3NA3140	3NE1225-0	3VL3725-.DC36-....	
	75	100	6SE6440-2UD37-5FA1	3NA3144	3NE1227-0	3VL3725-.DC36-....				
	90	125	6SE6440-2UD38-8FA1	–	–	3VL4731-.DC36-....				
110	150	6SE6440-2UD41-1FA1	–	3NE1230-0	–					
132	200	6SE6440-2UD41-3GA1	–	3NE1332-0	–					
160	250	6SE6440-2UD41-6GA1	–	3NE1333-0	3VL4740-.DC36-....					
200	300	6SE6440-2UD42-0GA1	–	3NE1435-0	3VL5750-.DC36-....					
3 AC 500 V to 600 V	0.75	1.0	6SE6440-2UE17-5CA1	6SE6400-0GP00-0CA0	3NA3803-6	●	3RV1021-1EA10			
	1.5	2.0	6SE6440-2UE21-5CA1				3RV1021-1GA10			
	2.2	3.0	6SE6440-2UE22-2CA1				3RV1021-1JA10			
	4.0	5.0	6SE6440-2UE24-0CA1	6SE6400-0GP00-0CA0	3NA3805-6	3RV1021-1KA10	3RV1021-4AA10			
	5.5	7.5	6SE6440-2UE25-5CA1				3RV1021-4BA10			
	7.5	10	6SE6440-2UE27-5CA1	6SE6400-0GP00-0CA0	3NA3810-6	3RV1021-4BA10	3RV1021-4DA10			
	11.0	15	6SE6440-2UE31-1CA1				3RV1031-4FA10			
	15.0	20	6SE6440-2UE31-5DA1				3RV1031-4HA10			
	18.5	25	6SE6440-2UE31-8DA1	3NA3814-6	3NE1803-0	3RV1042-4JA10				
	22	30	6SE6440-2UE32-2DA1	3NA3820-6	3NE1817-0	3RV1042-4KA10				
	30	40	6SE6440-2UE33-0EA1	3NA3822-6	3NE1818-0	3RV1042-4MA10				
	37	50	6SE6440-2UE33-7EA1	3NA3824-6	3NE1820-0	3RV1042-4MA10				
	45	60	6SE6440-2UE34-5FA1	–	–	3VL1712-.DD33-....				
	55	75	6SE6440-2UE35-5FA1	3NA3132-6	3NE1022-0	3VL1716-.DD33-....				
	75	100	6SE6440-2UE37-5FA1	3NA3136-6	3NE1224-0	3VL3720-.DC36-....				
						3VL3725-.DC36-....				

Selection and ordering data (continued)

Mains voltage	Output (CT)		Inverter with internal filter Class A	Order No. of options Additional EMC filter, Class B	Line commutating choke	LC filter	
	kW	hp					
1 AC 200 V to 240 V	0.12	0.16	6SE6440-2AB11-2AA1	6SE6400-2FS01-0AB0	6SE6400-3CC00-4AB3	–	
	0.25	0.33	6SE6440-2AB12-5AA1			–	
	0.37	0.50	6SE6440-2AB13-7AA1			6SE6400-3CC01-0AB3	–
	0.55	0.75	6SE6440-2AB15-5AA1	–	–	–	
	0.75	1.0	6SE6440-2AB17-5AA1	–	–	–	
	1.1	1.5	6SE6440-2AB21-1BA1	6SE6400-2FS02-6BB0	6SE6400-3CC02-6BB3	–	
	1.5	2.0	6SE6440-2AB21-5BA1			–	
	2.2	3.0	6SE6440-2AB22-2BA1			–	
	3.0	4.0	6SE6440-2AB23-0CA1	6SE6400-2FS03-5CB0	6SE6400-3CC03-5CB3	–	
	3 AC 200 V to 240 V	3.0	4.0	6SE6440-2AC23-0CA1	6SE6400-2FS03-8CD0	6SE6400-3CC01-7CC3	–
4.0		5.0	6SE6440-2AC24-0CA1	–	6SE6400-3CC03-5CD3	–	
5.5		7.5	6SE6440-2AC25-5CA1	–	–	–	
3 AC 380 V to 480 V	2.2	3.0	6SE6440-2AD22-2BA1	6SE6400-2FS01-6BD0	6SE6400-3CC01-0BD3	6SE6400-3TD01-0BD0	
	3.0	4.0	6SE6440-2AD23-0BA1				–
	4.0	5.0	6SE6440-2AD24-0BA1				6SE6400-3CC01-4BD3
	5.5	7.5	6SE6440-2AD25-5CA1	6SE6400-2FS03-8CD0	6SE6400-3CC02-2CD3	6SE6400-3TD03-2CD0	
	7.5	10	6SE6440-2AD27-5CA1				–
	11.0	15	6SE6440-2AD31-1CA1				6SE6400-3CC03-5CD3
	15.0	20	6SE6440-2AD31-5DA1	An inverter without filter must be selected to satisfy the EMC requirements of Class B. In addition, an appropriate EMC filter of Class B from Schaffner is required.	6SE6400-3CC04-4DD0	6SE6400-3TD03-7DD0	
	18.5	25	6SE6440-2AD31-8DA1		6SE6400-3CC05-2DD0	6SE6400-3TD04-8DD0	
	22	30	6SE6440-2AD32-2DA1		6SE6400-3CC08-3ED0	6SE6400-3TD06-1DD0	
	30	40	6SE6440-2AD33-0EA1		6SE6400-3CC11-2FD0	6SE6400-3TD07-2ED0	
	37	50	6SE6440-2AD33-7EA1		–	6SE6400-3TD11-5FD0	
	45	60	6SE6440-2AD34-5FA1		–	–	
	55	75	6SE6440-2AD35-5FA1		–	6SE6400-3TD15-0FD0	
	75	100	6SE6440-2AD37-5FA1		–	6SE6400-3CC11-7FD0	6SE6400-3TD18-0FD0
	Mains voltage	Output (CT)			Inverter with internal filter Class A	Order No. of options Output choke	Brake resistors
kW		hp					
1 AC 200 V to 240 V	0.12	0.16	6SE6440-2AB11-2AA1	6SE6400-3TC00-4AD3	6SE6400-4BC05-0AA0	6SE6400-0GP00-0AA0	
	0.25	0.33	6SE6440-2AB12-5AA1				–
	0.37	0.50	6SE6440-2AB13-7AA1				–
	0.55	0.75	6SE6440-2AB15-5AA1	–	–	–	
	0.75	1.0	6SE6440-2AB17-5AA1	–	–	–	
	1.1	1.5	6SE6440-2AB21-1BA1	6SE6400-3TC01-0BD3	6SE6400-4BC11-2BA0	6SE6400-0GP00-0BA0	
	1.5	2.0	6SE6440-2AB21-5BA1				–
	2.2	3.0	6SE6440-2AB22-2BA1				–
	3.0	4.0	6SE6440-2AB23-0CA1	6SE6400-3TC03-2CD3	6SE6400-4BC12-5CA0	6SE6400-0GP00-0CA0	
	3 AC 200 V to 240 V	3.0	4.0	6SE6440-2AC23-0CA1	6SE6400-3TC03-2CD3	6SE6400-4BC12-5CA0	6SE6400-0GP00-0CA0
4.0		5.0	6SE6440-2AC24-0CA1	–	6SE6400-4BC13-0CA0	–	
5.5		7.5	6SE6440-2AC25-5CA1	–	–	–	
3 AC 380 V to 480 V	2.2	3.0	6SE6440-2AD22-2BA1	6SE6400-3TC01-0BD3	6SE6400-4BD12-0BA0	6SE6400-0GP00-0BA0	
	3.0	4.0	6SE6440-2AD23-0BA1				–
	4.0	5.0	6SE6440-2AD24-0BA1				–
	5.5	7.5	6SE6440-2AD25-5CA1	6SE6400-3TC03-2CD3	6SE6400-4BD16-5CA0	6SE6400-0GP00-0CA0	
	7.5	10	6SE6440-2AD27-5CA1				–
	11.0	15	6SE6440-2AD31-1CA1				–
	15.0	20	6SE6440-2AD31-5DA1	6SE6400-3TC05-4DD0	6SE6400-4BD21-2DA0	Integrated as standard for shield connection of the control cable and the power cable.	
	18.5	25	6SE6440-2AD31-8DA1	6SE6400-3TC03-8DD0	–		
	22	30	6SE6440-2AD32-2DA1	6SE6400-3TC05-4DD0	–		
	30	40	6SE6440-2AD33-0EA1	6SE6400-3TC08-0ED0	6SE6400-4BD22-2EA0		
	37	50	6SE6440-2AD33-7EA1	6SE6400-3TC07-5ED0	–		
	45	60	6SE6440-2AD34-5FA1	6SE6400-3TC14-5FD0	6SE6400-4BD24-0FA0		
	55	75	6SE6440-2AD35-5FA1	6SE6400-3TC15-4FD0	–		
	75	100	6SE6440-2AD37-5FA1	6SE6400-3TC14-5FD0	–		

MICROMASTER 440

Options Variant dependent options

Selection and ordering data (continued)

Mains voltage	Output (CT)		Inverter with internal filter Class A	Order No. of the options Fuses (see Catalog LV 1)		Circuit-breaker (see Catalog LV 1)
	kW	hp		3NA3	3NE1 (9A)	
1 AC 200 V to 240 V	0.12	0.16	6SE6440-2AB11-2AA1	3NA3803	●	3RV1021-1EA10
	0.25	0.33	6SE6440-2AB12-5AA1			3RV1021-1HA10
	0.37	0.50	6SE6440-2AB13-7AA1			3RV1021-1JA10
	0.55	0.75	6SE6440-2AB15-5AA1	3NA3805		3RV1021-1KA10
	0.75	1.0	6SE6440-2AB17-5AA1			3RV1021-4AA10
	1.1	1.5	6SE6440-2AB21-1BA1	3NA3807		3RV1021-4DA10
	1.5	2.0	6SE6440-2AB21-5BA1			3RV1031-4EA10
	2.2	3.0	6SE6440-2AB22-2BA1	3NA3812		3RV1031-4FA10
	3.0	4.0	6SE6440-2AB23-0CA1	3NA3817		3RV1041-4JA10
3 AC 200 V to 240 V	3.0	4.0	6SE6440-2AC23-0CA1	3NA3810	●	3RV1031-4EA10
	4.0	5.0	6SE6440-2AC24-0CA1	3NA3812		3RV1031-4FA10
	5.5	7.5	6SE6440-2AC25-5CA1	3NA3814		3RV1031-4HA10
3 AC 380 V to 480 V	2.2	3.0	6SE6440-2AD22-2BA1	3NA3805	●	3RV1021-1KA10
	3.0	4.0	6SE6440-2AD23-0BA1			3RV1021-4AA10
	4.0	5.0	6SE6440-2AD24-0BA1	3NA3807		3RV1021-4BA10
	5.5	7.5	6SE6440-2AD25-5CA1			3RV1031-4EA10
	7.5	10	6SE6440-2AD27-5CA1	3NA3812		3RV1031-4FA10
	11.0	15	6SE6440-2AD31-1CA1	3NA3814		3RV1031-4HA10
	15.0	20	6SE6440-2AD31-5DA1	3NA3820	3NE1817-0	3RV1042-4KA10
	18.5	25	6SE6440-2AD31-8DA1	3NA3822	3NE1818-0	
	22	30	6SE6440-2AD32-2DA1	3NA3824	3NE1820-0	3RV1042-4MA10
	30	40	6SE6440-2AD33-0EA1	3NA3830	3NE1021-0	3VL1712-.DD33-....
	37	50	6SE6440-2AD33-7EA1	3NA3832	3NE1022-0	3VL1716-.DD33-....
	45	60	6SE6440-2AD34-5FA1	3NA3836	3NE1224-0	3VL3720-.DC36-....
	55	75	6SE6440-2AD35-5FA1	3NA3140	3NE1225-0	3VL3725-.DC36-....
75	100	6SE6440-2AD37-5FA1	3NA3144	3NE1227-0	3VL4731-.DC36-....	

● Use in America requires
Ⓢ-listed fuses such as the
Class NON/NOS range
from Bussmann.

Overview**Basic Operator Panel (BOP)**

With the BOP, individual parameter settings can be made. Values and units are shown on a 5-digit display.



Basic Operator Panel (BOP)

A BOP can be used for several inverters. It can be directly mounted on the inverter or in a control cabinet door using a mounting kit.

Advanced Operator Panel (AOP)

The AOP enables MICROMASTER 440 parameter kits to be easily read and modified. In contrast to the BOP, the value and meaning of the parameters can be directly displayed as plain text in several languages by fast scrolling of the address.



Advanced Operator Panel (AOP)

The AOP is directly plugged into the inverter, or communicates with the latter through a door mounting kit. Together with the "AOP door mounting kit for multiple inverters", the AOP permits bus communication with up to 30 inverters at a transmission rate of 38 kbaud. (RS485, USS).

For servicing purposes, the AOP furthermore supports the download and upload of complete parameter kits.

Asian Advanced Operator Panel (AAOP)

The AAOP is the Chinese version of the AOP operator panel. It has an enhanced display and supports the operating languages of Chinese (simplified) and English.



Asian Advanced Operator Panel (AAOP)

Cyrillic Advanced Operator Panel (CAOP)

The CAOP is the Cyrillic version of the AOP Advanced Operator Panel. It supports the Cyrillic, German and English operator languages.

PROFIBUS module

For a complete PROFIBUS connection with up to ≤ 12 Mbaud. Remote control of the inverter is possible with the PROFIBUS module. Remote control and operation at the inverter can be combined using an operator panel plugged onto the PROFIBUS module. The PROFIBUS module can be supplied by an external 24 V DC power supply and is thus also active when the inverter is disconnected from the power supply.

Connection by means of a 9-pin Sub-D connector (available as an option).

DeviceNet module

For networking the inverters to the DeviceNet fieldbus system widely used on the American market. A maximum transmission rate of 500 kbaud is possible. Remote control of the inverter is possible with the DeviceNet module. Remote control and operation at the inverter can be combined using an operator panel plugged onto the DeviceNet module.

The connection to the DeviceNet bus system is made using a 5-pin connector with terminal strip.

CANopen module

Using the CANopen communications module, an inverter can be linked to the CANopen fieldbus system and remote control is then possible.

Remote control and operation at the inverter can be combined using an operator panel plugged onto the CANopen module.

The module is connected to the bus system through a 9-pin Sub-D connector.

Pulse encoder evaluation module

The pulse encoder evaluation module permits direct connection of the most widely encountered digital pulse encoders to the inverter.

They offer the following functions:

- Zero speed at full load torque
- Extremely accurate speed control
- Increased dynamic response of speed and torque control.

This module can be used with HTL and TTL pulse encoders (High voltage Transistor Logic, 24 V and Transistor Logic, 5 V).

MICROMASTER 440

Options

Variant independent options

Overview (continued)

Connection kit for PC to inverter

For controlling an inverter directly from a PC if the appropriate software has been installed (e.g. STARTER). Isolated RS-232 adapter module for reliable point-to-point connection to a PC. Includes a Sub-D connector and an RS-232 standard cable (3 m).

Connection kit for PC to AOP

For connecting a PC to an AOP or AAOP. Offline programming of inverters and archiving of parameter kits possible. Includes a desktop attachment kit for an AOP or AAOP, an RS-232 standard cable (3 m) with Sub-D connectors and a universal power supply unit.

Operator panel door mounting kit for single inverter

For mounting an operator panel in a control cabinet door. Degree of protection IP56. Contains a cable adapter module with screwless terminals for use with user's own RS-232 cables ¹⁾.

AOP door mounting kit for multiple inverters (USS)

For mounting an AOP or AAOP in a control cabinet door. Degree of protection IP56. The AOP or AAOP can communicate with several inverters by means of the RS-485 USS protocol. The 4-pin connecting cable from the AOP or AAOP to the RS-485 terminals of the inverter and to the 24 V user terminal strip is not included ²⁾.

Start-up tools

- **STARTER**
Starter is graphic start-up software for guided start-up for MICROMASTER 410/420/430/440 frequency inverters under Windows 2000/XP Professional. Parameter lists can be read out, altered, stored, entered and printed.
- **DriveMonitor**
is a start-up software for list-oriented programming of frequency inverters. This program executes under Windows 98/NT/2000/ME/XP Professional.

Both programs are included on the Docu DVD which is provided with every inverter.

Selection and ordering data

The options listed here are suitable for all MICROMASTER 440 inverters.

Options	Order No.	
Basic Operator Panel (BOP)	6SE6400-0BP00-0AA0	
Advanced Operator Panel (AOP)	6SE6400-0AP00-0AA1	
Asian Advanced Operator Panel (AAOP)	6SE6400-0AP00-0AB0	
Cyrillic Advanced Operator Panel (CAOP)	6SE6400-0AP00-0CA0	
PROFIBUS module	6SE6400-1PB00-0AA0	
DeviceNet module	6SE6400-1DN00-0AA0	
CANopen module	6SE6400-1CB00-0AA0	
Pulse encoder evaluation module	6SE6400-0EN00-0AA0	
RS485/PROFIBUS bus connector	6GK1500-0FC00	
Connection kit for PC to inverter	6SE6400-1PC00-0AA0	
Connection kit for PC to AOP	6SE6400-0PA00-0AA0	
Operator panel door mounting kit for single inverter	6SE6400-0PM00-0AA0	
AOP door mounting kit for multiple inverters (USS)	6SE6400-0MD00-0AA0	
Start-up tool STARTER on DVD	6SL3072-0AA00-0AG0	Available on the Internet at: http://support.automation.siemens.com/WW/view/en/10804985/133100

1) A shielded cable of type Belden 8132 (28 AWG) is recommended. The maximum cable length is 5 m for RS-232.

2) A shielded cable of type Belden 8132 (28 AWG) is recommended. The maximum cable length is 10 m for RS-485.

Technical data



PROFIBUS module
6SE6400-1PB00-0AA0**DeviceNet module**
6SE6400-1DN00-0AA0

Size (height x width x depth)	161 mm x 73 mm x 46 mm	
Degree of protection	IP20	
Degree of pollution	2 to IEC 60664-1 (DIN VDE 0110/T1), no condensation permitted during operation	
Strain resistance	to IEC 60068-2-6 (if module is installed correctly)	
• Stationary	Deflection	0.15 mm in the frequency range of 10 Hz to 58 Hz
	Acceleration	19.6 m/s ² in the frequency range of 58 Hz to 500 Hz
• Transport	Deflection	3.5 mm in the frequency range of 5 Hz to 9 Hz
	Acceleration	9.8 m/s ² in the frequency range of 9 Hz to 500 Hz
Climatic category (during operation)	3K3 to IEC 60721-3-3	
Cooling method	Natural air cooling	
Permissible ambient or cooling agent temperature		
• Operation	-10 °C to +50 °C (+14 °F to +122 °F)	
• Storage and transport	-25 °C to +70 °C (-13 °F to +158 °F)	
Relative humidity (permissible humidity rating)		
• Operation	≤ 85 % (non-condensing)	
• Storage and transport	≤ 95 %	
Electromagnetic compatibility	Emission	to EN 55011 (1991) Class A
	Interference	to IEC 60801-3 and EN 61000-4-3
Power supply	6.5 V ± 5 %, max. 300 mA, internal from inverter or 24 V ± 10 %, max. 350 mA, external	6.5 V ± 5 %, max. 300 mA internal from inverter or 24 V, max. 60 mA from DeviceNet-Bus
Output voltage	5 V ± 10 %, max. 100 mA, galvanically isolated supply • for terminating the serial interface bus or • for supplying the OLP (Optical Link Plug)	–
Data transmission rate	max. 12 Mbaud	125, 250 and 500 Kbaud

MICROMASTER 440

Options Variant independent options

Technical data (continued)

		CANopen module 6SE6400-1CB00-0AA0	Pulse encoder evaluation module 6SE6400-0EN00-0AA0
			
Size (height x width x depth)		161 mm x 73 mm x 46 mm	161 mm x 73 mm x 42 mm
Degree of protection		IP20	
Degree of pollution		2 to IEC 60 664-1 (DIN VDE 0110/T1), no condensation permitted during operation	
Strain resistance		to IEC 60 068-2-6 (if module is installed correctly)	
• Stationary	Deflection	0.15 mm in the frequency range of 10 Hz to 58 Hz	
	Acceleration	19.6 m/s ² in the frequency range of 58 Hz to 500 Hz	
• Transport	Deflection	3.5 mm in the frequency range of 5 Hz to 9 Hz	
	Acceleration	9.8 m/s ² in the frequency range of 9 Hz to 500 Hz	
Climatic category (during operation)		3K3 to IEC 60 721-3-3	
Cooling method		Natural air cooling	
Permissible ambient or cooling agent temperature			
• Operation		-10 °C to +50 °C (+14 °F to +122 °F)	-10 °C to +50 °C (+14 °F to +122 °F)
• Storage		-40 °C to +70 °C (-40 °F to +158 °F)	-20 °C to +70 °C (-14 °F to +158 °F)
• Transportation		-25 °C to +70 °C (-13 °F to +158 °F)	-20 °C to +70 °C (-14 °F to +158 °F)
Electromagnetic compatibility		to EN 55 011 (1991) Class A	
	Emission	to IEC 60 801-3 and EN 61 000-4-3	
Relative humidity (permissible humidity rating)			
• Operation		≤ 85 % (non-condensing)	
• Storage and transport		≤ 95 %	
Power supply		The CAN bus is supplied from the inverter power supply	5 V ± 5 %, 330 mA or 18 V non-regulated, 140 mA, short-circuit proof
Data transmission rate		10, 20, 50, 125, 250, 500, 800 kbaud and 1 Mbaud	-
Pulse frequency		-	max. 300 kHz

Selection and ordering data

Type of documentation	Language	Order No.
Docu pack , supplied with each inverter, containing DVD ¹⁾ and Getting Started Guide ²⁾ (paper version)	Multilanguage	6SE6400-5AD00-1AP1
Operating instructions (paper version)	German, English, French, Italian, Spanish Available as pdf file on the Internet at http://support.automation.siemens.com/WW/view/en/10804926/133300	
Parameter list (paper version)	German, English, French, Italian, Spanish Available as pdf file on the Internet at http://support.automation.siemens.com/WW/view/en/10804926/133300	

1) The DVD contains operating instructions, parameter list, commissioning tools STARTER and DriveMonitor, multilanguage.

Available on the Internet: DriveMonitor at <http://support.automation.siemens.com/WW/view/en/10804984/133100>

STARTER at <http://support.automation.siemens.com/WW/view/en/10804985/133100>

2) Available on the Internet at <http://support.automation.siemens.com/WW/view/en/10804926/133300>

MICROMASTER 440

Dimension drawings

MICROMASTER 440 inverter

Frame size	1/3 AC 200 V to 240 V	3 AC 380 V to 480 V	3 AC 500 V to 600 V
A	0.12 kW to 0.75 kW	0.37 kW to 1.5 kW	–
B	1.1 kW to 2.2 kW	2.2 kW to 4 kW	–
C	3 kW to 5.5 kW	5.5 kW to 11 kW	0.75 kW to 11 kW

The specified outputs are valid for CT mode.

Note:
The inverters must not be mounted horizontally. But the inverters can be mounted without lateral spacing.

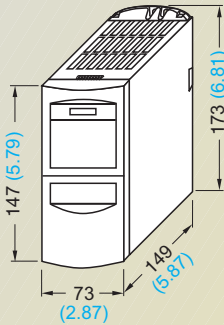

Inverter frame size **A**

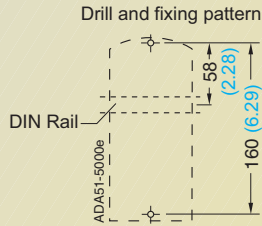

Fixing with 2 x M4 bolts, 2 x M4 nuts, 2 x M4 washers or by snapping onto a rail
Tightening torque with washers fitted: 2.5 Nm
Ventilation clearance required
Top and bottom: 100 mm

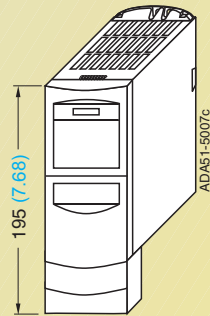

Inverter frame size **A** with gland plate

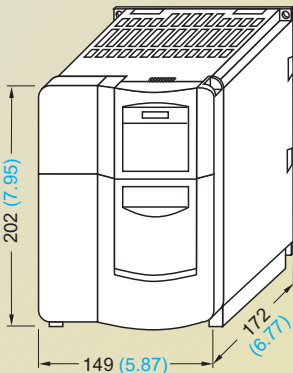

Inverter frame size **B**



Fixing with 4 x M4 bolts, 4 x M4 nuts, 4 x M4 washers
Tightening torque with washers fitted: 2.5 Nm
Ventilation clearance required
Top and bottom: 100 mm

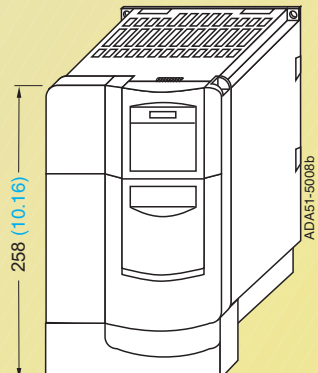

Inverter frame size **B** with gland plate

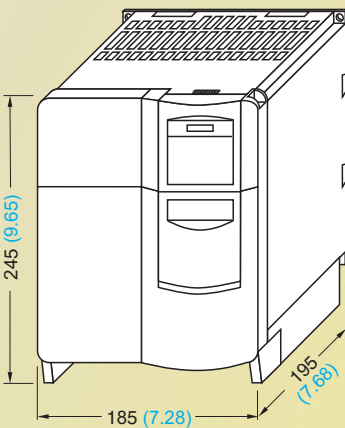

Inverter frame size **C**

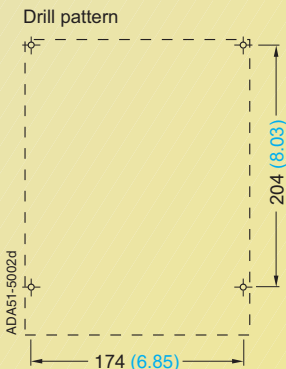

Fixing with 4 x M5 bolts, 4 x M5 nuts, 4 x M5 washers
Tightening torque with washers fitted: 3.0 Nm
Ventilation clearance required
Top and bottom: 100 mm

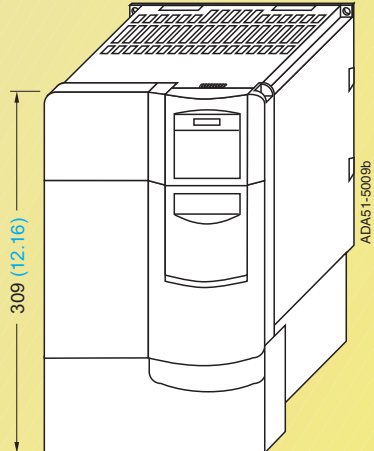

Inverter frame size **C** with gland plate

With the communications module, the mounting depth increases by 23 mm (0.91 inches). If a pulse encoder evaluation module is mounted in addition, the installation depth increases by another 23 mm (0.91 inches).

All dimensions in mm (values in brackets are in inches)

4

MICROMASTER 440 inverter (continued)

Frame size	3 AC 200 V to 240 V	3 AC 380 V to 480 V	3 AC 500 V to 600 V
D	7.5 kW to 15 kW	15 kW to 22 kW	15 kW to 22 kW
E	18.5 kW to 22 kW	30 kW to 37 kW	30 kW to 37 kW
F	30 kW to 45 kW	45 kW to 75 kW	45 kW to 75 kW

Note:
The inverters must not be mounted horizontally. But the inverters can be mounted without lateral spacing.

The specified outputs are valid for CT mode.

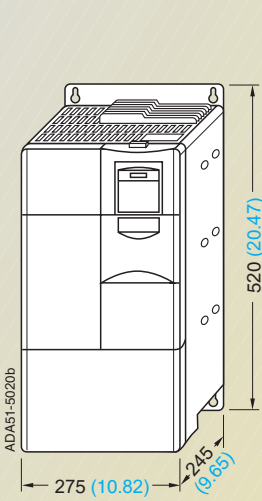

Inverter frame size D

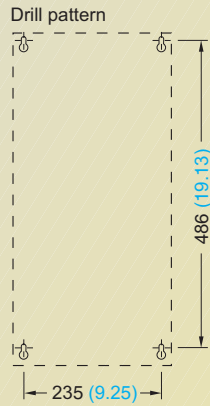

Fixing with
4 x M8 bolts, 4 x M8 nuts,
4 x M8 washers
Tightening torque with washers
fitted: 13 Nm
Ventilation clearance required
Top and bottom: 300 mm

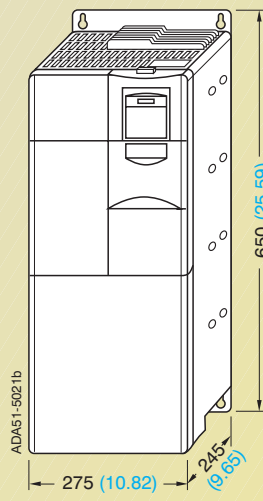

Inverter frame size E



Fixing with
4 x M8 bolts, 4 x M8 nuts,
4 x M8 washers
Tightening torque with washers
fitted: 13 Nm
Ventilation clearance required
Top and bottom: 300 mm

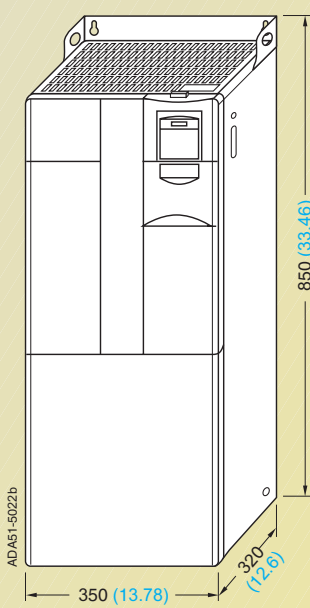

Inverter frame size F without filter



Fixing with
4 x M8 bolts, 4 x M8 nuts,
4 x M8 washers
Tightening torque with washers
fitted: 13 Nm
Ventilation clearance required
Top and bottom: 350 mm

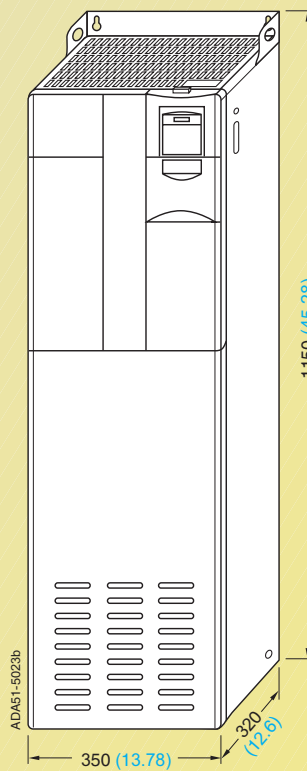

Inverter frame size F with filter



Fixing with
4 x M8 bolts, 4 x M8 nuts,
4 x M8 washers
Tightening torque with washers
fitted: 13 Nm
Ventilation clearance required
Top and bottom: 350 mm

All dimensions in mm (values in brackets are in inches)

MICROMASTER 440

Dimension drawings

MICROMASTER 440 inverter (continued)

Frame size	3 AC 380 V to 480 V
FX	90 kW to 110 kW
GX	132 kW to 200 kW

Note:
The inverters must not be mounted horizontally. But the inverters can be mounted without lateral spacing.

The specified outputs are valid for CT mode.

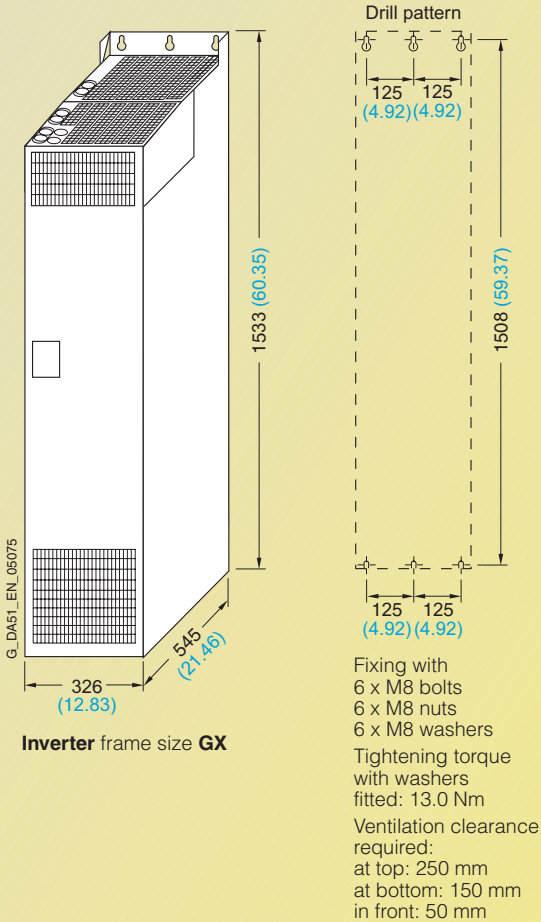
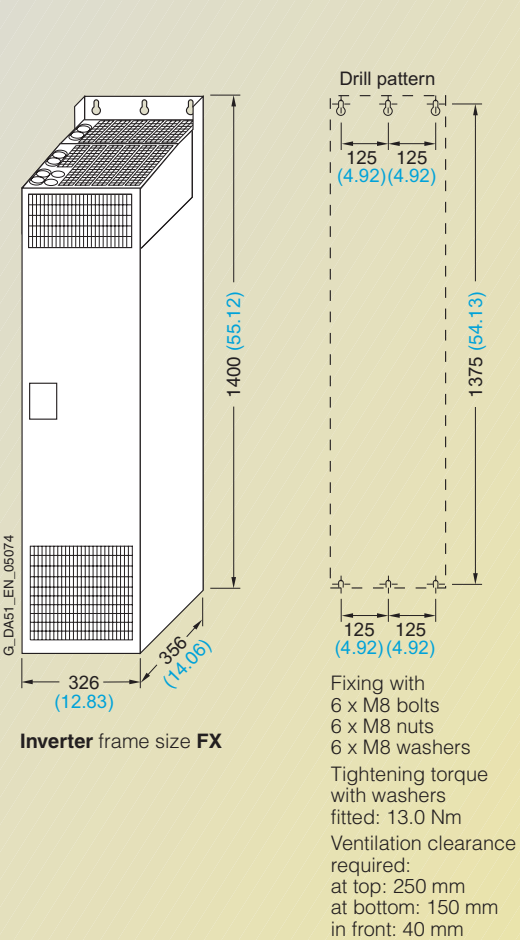

All dimensions in mm (values in brackets are in inches)

EMC filter

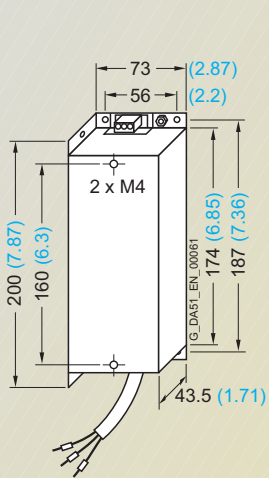

EMC filter for frame size **A**

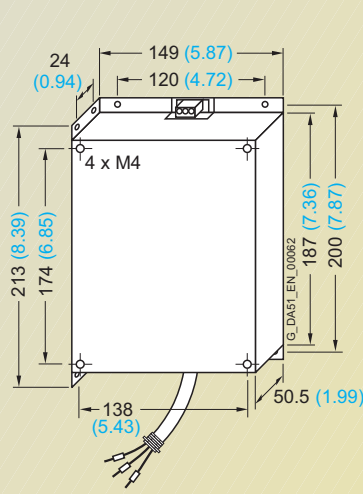

For frame size **B**

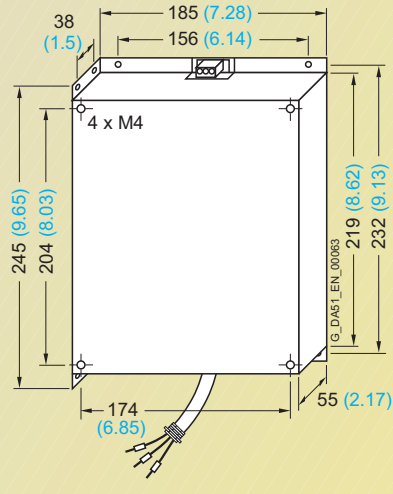

For frame size **C**

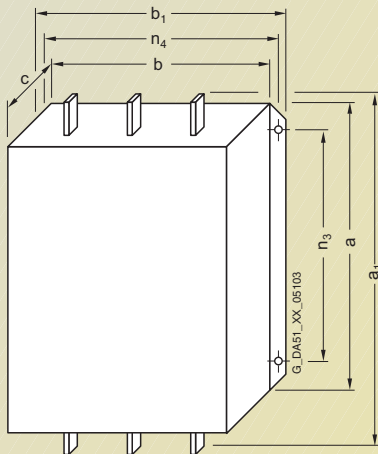

EMC filter Class A Type 6SL3000-	for inverter Frame size (FS)	Dimensions							Weight, approx kg
		a	a ₁	b	b ₁	c	n ₃	n ₄	
OBE32-5AAO	FX	270 (10.63)	360 (14.17)	200 (7.87)	240 (9.45)	116 (4.57)	210 (8.27)	220 (8.66)	12.3
OBE34-4AAO	GX/GX	270 (10.63)	360 (14.17)	200 (7.87)	240 (9.45)	116 (4.57)	210 (8.27)	220 (8.66)	12.3
OBE36-0AAO	GX	310 (12.2)	400 (15.75)	215 (8.46)	265 (10.43)	140 (5.51)	250 (9.84)	240 (9.45)	19.0

EMC filter for frame sizes **FX** and **GX**

All dimensions in mm (values in brackets are in inches)

MICROMASTER 440

Dimension drawings

LC filter

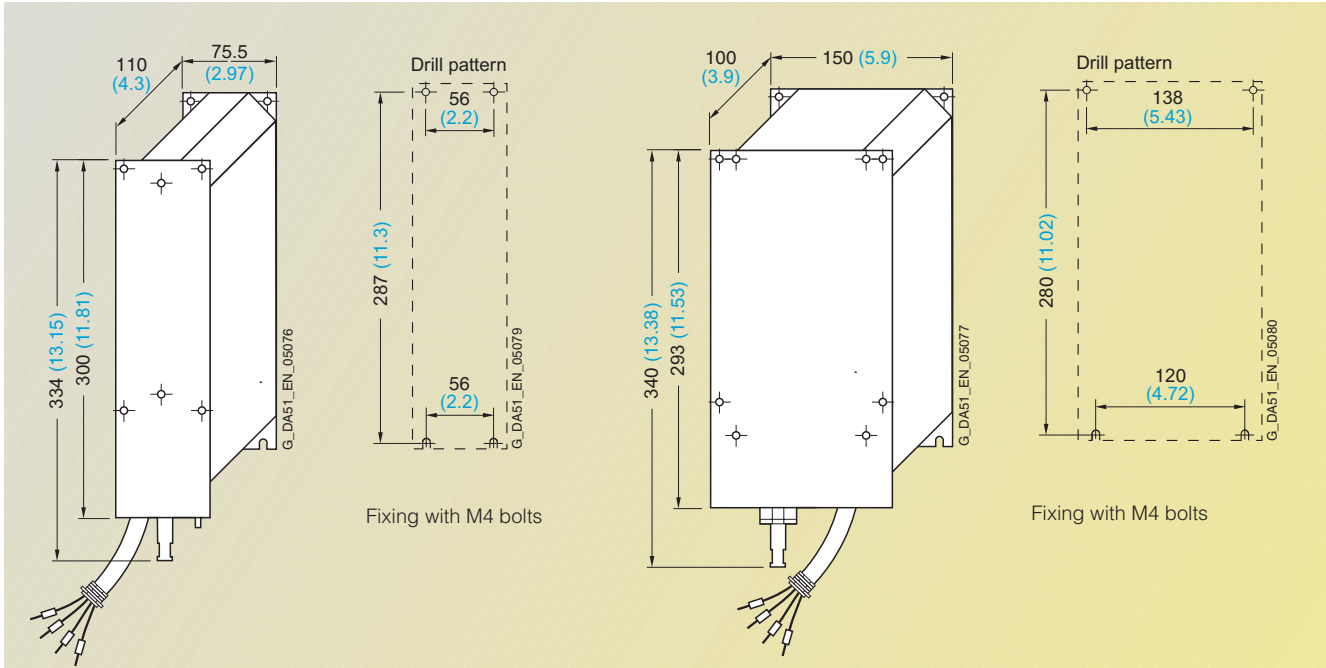

LC filter for frame size **A**

For frame size **B**

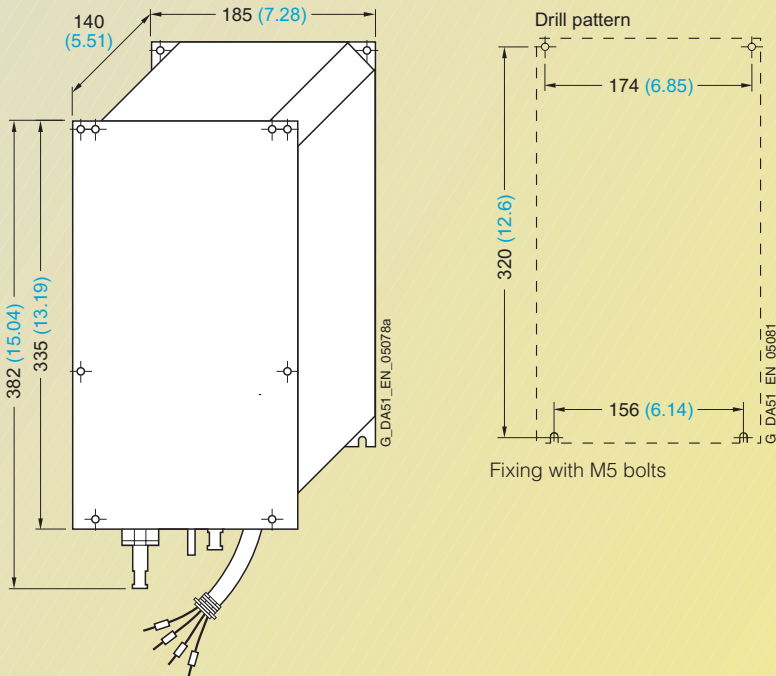

LC filter for frame size **C**

All dimensions in mm (values in brackets are in inches)

Dimension drawings

LC filter

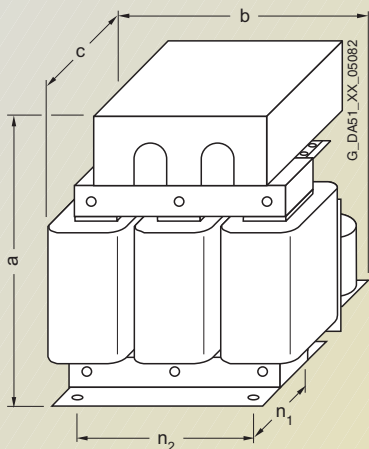

Fixing with M10 bolts

LC filter for frame sizes **D** to **F**

LC filter Type	for inverter Frame size (FS)	Dimensions					Weight, approx kg
		a	b	c	n ₁	n ₂	
6SE6400-3TD03-7DD0	D	278 (10.94)	240 (9.45)	230 (9.06)	115 (4.53)	190 (7.48)	21.0
6SE6400-3TD04-8DD0	D	290 (11.42)	240 (9.45)	240 (9.45)	125 (4.92)	190 (7.48)	26.0
6SE6400-3TD06-1DD0	D	345 (13.58)	300 (11.81)	220 (8.66)	120 (4.72)	240 (9.45)	34.0
6SE6400-3TD02-3DE0	D	280 (11.02)	240 (9.45)	240 (9.45)	125 (4.92)	190 (7.48)	26.1
6SE6400-3TD03-2DE0	D	300 (11.81)	300 (11.81)	235 (9.25)	133 (5.24)	240 (9.45)	39.5
6SE6400-3TD03-7DE0	D	310 (12.2)	300 (11.81)	250 (9.84)	145 (5.71)	240 (9.45)	42.0
6SE6400-3TD07-2ED0	E	355 (13.98)	300 (11.81)	235 (9.25)	145 (5.71)	240 (9.45)	49.5
6SE6400-3TD04-8EE0	E	345 (13.58)	300 (11.81)	260 (10.24)	160 (6.3)	240 (9.45)	48.5
6SE6400-3TD06-1EE0	E	345 (13.58)	300 (11.81)	275 (10.83)	171 (6.73)	240 (9.45)	57.5
6SE6400-3TD11-5FD0	E/F	460 (18.11)	360 (14.17)	235 (9.25)	125 (4.92)	264 (10.39)	67.0
6SE6400-3TD15-0FD0	F	460 (18.11)	360 (14.17)	250 (9.84)	140 (5.51)	264 (10.39)	75.0
6SE6400-3TD18-0FD0	F	520 (20.47)	420 (16.54)	290 (11.42)	173 (6.81)	316 (12.44)	77.5
6SE6400-3TD07-1FE0	F	380 (14.96)	300 (11.81)	285 (11.22)	171 (6.73)	240 (9.45)	70.5
6SE6400-3TD10-0FE0	F	460 (18.11)	360 (14.17)	250 (9.84)	140 (5.11)	264 (10.39)	70.5
6SE6400-3TD11-5FE0	F	515 (20.28)	420 (16.54)	290 (11.42)	173 (6.81)	316 (12.44)	125.5

All dimensions in mm (values in brackets are in inches)

MICROMASTER 440

Dimension drawings

Sinusoidal filter

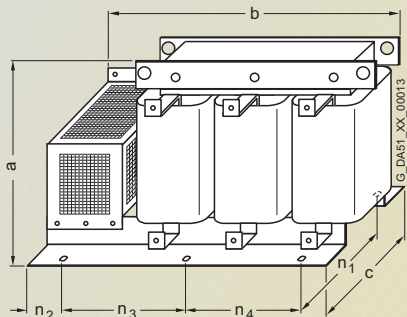

Sinusoidal filter for frame sizes **FX** and **GX**

Sinusoidal filter Type 6SL3000-	for inverter Frame size (FS)	Dimensions							Weight (max.) kg
		a	b	c	n ₁	n ₂	n ₃	n ₄	
2CE32-3AA0	FX	300 (11.81)	620 (24.41)	320 (12.6)	280 (11.02)	105 (4.13)	225 (8.86)	150 (5.91)	135.0
2CE32-8AA0	GX	300 (11.81)	620 (24.41)	320 (12.6)	280 (11.02)	105 (4.13)	225 (8.86)	150 (5.91)	138.0

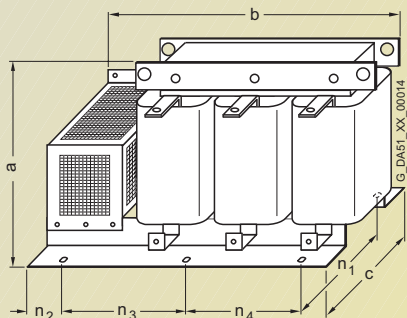

Sinusoidal filter for frame size **GX**

Sinusoidal filter Type 6SL3000-	for inverter Frame size (FS)	Dimensions							Weight (max.) kg
		a	b	c	n ₁	n ₂	n ₃	n ₄	
2CE33-3AA0	GX	370 (14.57)	620 (24.41)	360 (14.17)	320 (12.6)	105 (4.13)	225 (8.86)	150 (5.91)	144.0
2CE34-1AA0	GX	370 (14.57)	620 (24.41)	360 (14.17)	320 (12.6)	105 (4.13)	225 (8.86)	150 (5.91)	208.0

4

All dimensions in mm (values in brackets are in inches)

Line commutating chokes

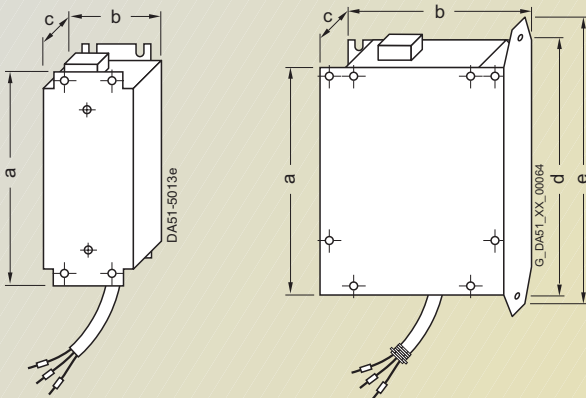

Line commutating choke for frame size **A**

For frame sizes **B** and **C**

Line commutating choke for	Dimensions					Weight (max.) kg
	a	b	c	d	e	
Frame size A	200 (7.87)	75.5 (2.97)	50 (1.97)	–	–	1.4
Frame size B	213 (8.39)	150 (5.91)	50 (1.97)	220 (8.66)	233 (9.17)	2.2
Frame size C (380–480 V)	245 (9.65)	185 (7.28)	50 (1.97)	264 (10.39)	280 (11.02)	5.1
Frame size C (500–600 V, 0.75–1.5 kW)	245 (9.65)	185 (7.28)	50 (1.97)	264 (10.39)	280 (11.02)	3.8
Frame size C (500–600 V, 2.2–4 kW)	245 (9.65)	185 (7.28)	50 (1.97)	264 (10.39)	280 (11.02)	4.0
Frame size C (500–600 V, 5.5–11 kW)	245 (9.65)	185 (7.28)	80 (3.15)	264 (10.39)	280 (11.02)	8.0

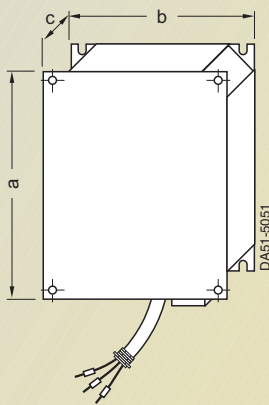

Line commutating choke for frame sizes **D** and **E**

Line commutating choke for	Dimensions			Weight (max.) kg
	a	b	c	
Frame size D	520 (20.47)	275 (10.83)	85 (3.35)	9.5
Frame size E	650 (25.59)	275 (10.83)	95 (3.74)	17.0

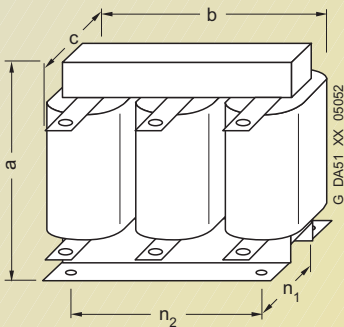

Line commutating choke for inverter frame size **F**

Line commutating choke Type	for inverter Frame size (FS)	Dimensions					Weight (max.) kg
		a	b	c	n ₁	n ₂	
6SE6400-3CC11-....	F	228 (8.98)	240 (9.45)	141 (5.55)	95 (3.74)	185 (7.28)	25.0

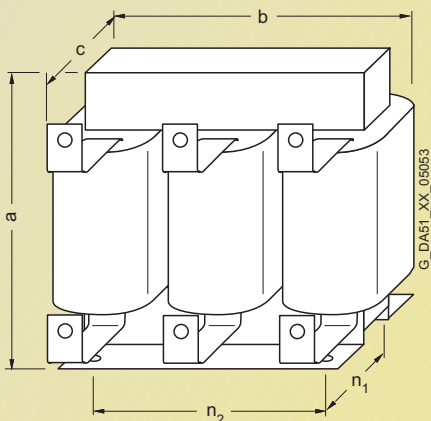

Line commutating choke for inverters of frame sizes **FX** and **GX**

Line commutating choke Type	for inverter Frame size (FS)	Dimensions					Weight (max.) kg
		a	b	c	n ₁	n ₂	
0CE32-....	FX	248 (9.76)	255 (10.04)	203 (7.99)	101 (3.98)	200 (7.87)	24.0
0CE33-....	GX	248 (9.76)	255 (10.04)	203 (7.99)	101 (3.98)	200 (7.87)	25.0
0CE35-....	GX	269 (10.59)	275 (10.83)	210 (8.27)	118 (4.65)	224 (8.82)	35.0

All dimensions in mm (values in brackets are in inches)

MICROMASTER 440

Dimension drawings

Output chokes

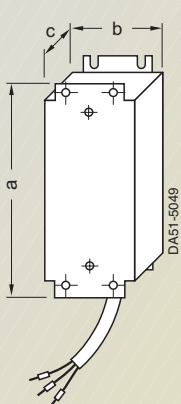

Output choke
for frame size **A**
6SE6400-3TC00-4AD2
6SE6400-3TC00-4AD3

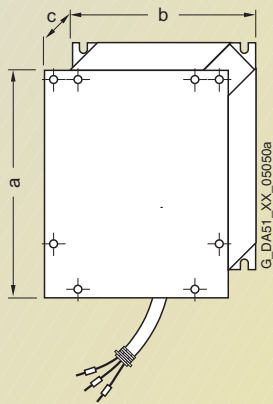

For frame sizes **B** and **C**
6SE6400-3TC01-0BD3
6SE6400-3TC01-8CE3
6SE6400-3TC03-2CD3

Output choke Type 6SE6400-	Dimensions			Weight (max.) kg
	a	b	c	
3TC00-4AD2	200 (7.87)	75.5 (2.97)	110 (4.33)	1.9
3TC00-4AD3	200 (7.87)	75.5 (2.97)	50 (1.97)	1.3
3TC01-0BD3	213 (8.39)	150 (5.91)	80 (3.15)	4.1
3TC01-8CE3	245 (9.65)	185 (7.28)	110 (4.33)	10.8
3TC03-2CD3	245 (9.65)	185 (7.28)	80 (3.15)	6.6

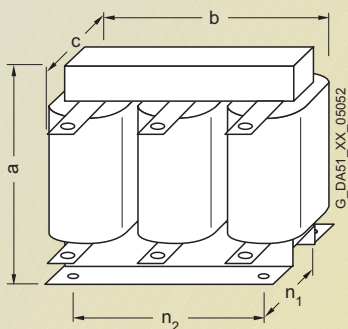

Output chokes
for inverters of frame sizes **D**, **E** and **F**

Output choke Type 6SE6400-	for inverter Frame size (FS)	Dimensions			to DIN 41 308		Weight (max.) kg
		a	b	c	n ₁	n ₂	
3TC03-2DE0	D	210 (8.27)	225 (8.86)	179 (7.05)	94 (3.70)	176 (6.93)	16.0
3TC03-8DD0	D	210 (8.27)	225 (8.86)	179 (7.05)	94 (3.70)	176 (6.93)	16.1
3TC05-4DD0	D	210 (8.27)	225 (8.86)	150 (5.91)	70 (2.76)	176 (6.93)	10.7
3TC06-2FE0	F	269 (10.59)	300 (11.81)	220 (8.66)	118 (4.65)	224 (8.82)	33.9
3TC07-5ED0	E	248 (9.76)	270 (10.63)	209 (8.23)	101 (3.98)	200 (7.87)	24.9
3TC08-0ED0	E	210 (8.27)	225 (8.86)	150 (5.91)	70 (2.76)	176 (6.93)	10.4
3TC08-8FE0	F	321 (12.64)	350 (13.78)	288 (11.34)	138 (5.43)	264 (10.39)	51.5
3TC14-5FD0	F	321 (12.64)	350 (13.78)	288 (11.34)	138 (5.43)	264 (10.39)	51.5
3TC15-4FD0	F	248 (9.76)	270 (10.63)	209 (8.23)	101 (3.98)	200 (7.87)	24.0

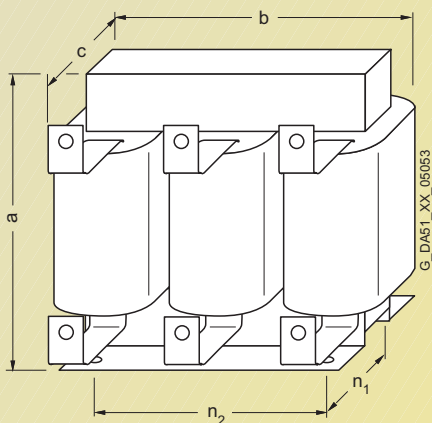

Output chokes
for inverters of frame sizes **FX** and **GX**

Output choke Type 6SL3000-	for inverter Frame size (FS)	Dimensions					Weight (max.) kg
		a	b	c	n ₁	n ₂	
2BE32-1AA0	FX	285 (11.22)	300 (11.81)	257 (10.12)	163 (6.42)	224 (8.82)	60.0
2BE32-6AA0	FX	315 (12.4)	300 (11.81)	277 (10.91)	183 (7.2)	224 (8.82)	66.0
2BE33-2AA0	GX	285 (11.22)	300 (11.81)	257 (10.12)	163 (6.42)	224 (8.82)	62.0
2BE33-8AA0	GX	285 (11.22)	300 (11.81)	277 (10.91)	183 (7.2)	224 (8.82)	73.0
2BE35-0AA0	GX	365 (14.37)	300 (11.81)	277 (10.91)	183 (7.2)	224 (8.82)	100.0

All dimensions in mm (values in brackets are in inches)

4

Brake resistors

Fig. 1:

Frame sizes **A, B**
Frame sizes **C, D, E, F**

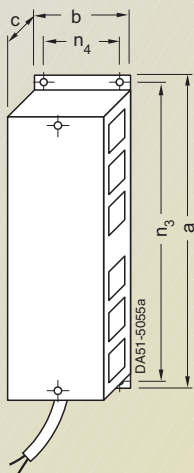

Fig. 2:

Fastening hole: circular hole \varnothing 5.2 mm
Fastening hole: slotted hole 6 x 12 mm
or circular hole \varnothing 6.5 mm

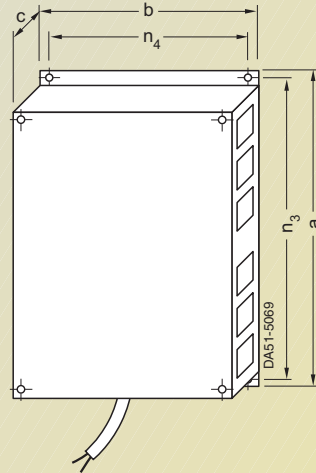
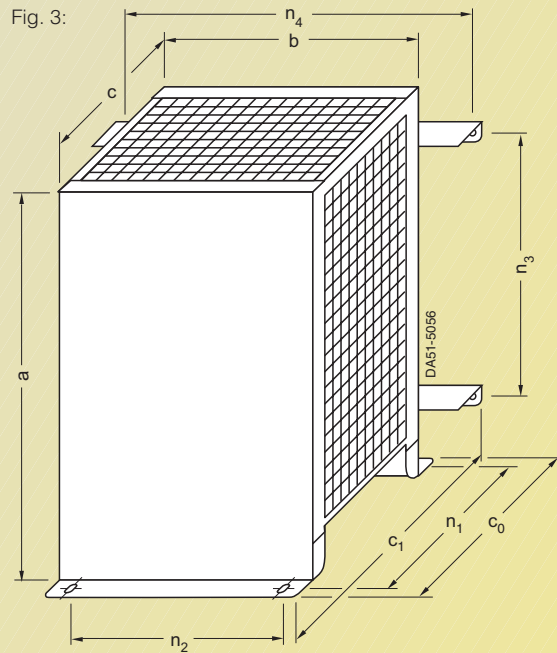

Fig. 3:



Brake resistors Type 6SE6400-	Resistor Ohm	for inverter Frame size (FS)	Figure No.	Dimensions					For floor mounting		For wall mounting		Weight (max.) kg
				a	b	c	c ₀	c ₁	n ₁	n ₂	n ₃	n ₄	
4BC05-0AA0	180	A	1	230 (9.06)	72 (2.83)	43.5 (1.71)	-	-	-	-	217 (8.54)	56 (2.20)	1.0
4BC11-2BA0	68	B	2	239 (9.41)	149 (5.87)	43.5 (1.71)	-	-	-	-	226 (8.90)	133 (5.24)	1.6
4BC12-5CA0	39	C	3	285 (11.22)	185 (7.28)	150 (5.91)	185 (7.28)	217 (8.54)	170 (6.69)	145 (5.71)	200 (7.87)	230 (9.06)	3.8
4BC13-0CA0	27	C	3	285 (11.22)	185 (7.28)	150 (5.91)	185 (7.28)	217 (8.54)	170 (6.69)	145 (5.71)	200 (7.87)	230 (9.06)	3.8
4BC18-0DA0	10	D	3	515 (20.28)	270 (10.63)	175 (6.89)	210 (8.27)	242 (9.53)	195 (7.68)	205 (8.07)	350 (13.78)	315 (12.40)	7.4
4BC21-2EA0	6.8	E	3	645 (25.39)	270 (10.63)	175 (6.89)	210 (8.27)	242 (9.53)	195 (7.68)	205 (8.07)	480 (18.90)	315 (12.40)	10.6
4BC22-5FA0	3.3	F	3	650 (25.59)	395 (15.55)	315 (12.40)	350 (13.78)	382 (15.04)	335 (13.19)	270 (10.63)	510 (20.08)	435 (17.13)	16.7
4BD11-0AA0	390	A	1	230 (9.06)	72 (2.83)	43.5 (1.71)	-	-	-	-	217 (8.54)	56 (2.20)	1.0
4BD12-0BA0	160	B	2	239 (9.41)	149 (5.87)	43.5 (1.71)	-	-	-	-	226 (8.90)	133 (5.24)	1.6
4BD16-5CA0	56	C	3	285 (11.22)	185 (7.28)	150 (5.91)	185 (7.28)	217 (8.54)	170 (6.69)	145 (5.71)	200 (7.87)	230 (9.06)	3.8
4BD21-2DA0	27	D	3	515 (20.28)	270 (10.63)	175 (6.89)	210 (8.27)	242 (9.53)	195 (7.68)	205 (8.07)	350 (13.78)	315 (12.40)	7.4
4BD22-2EA0	15	E	3	645 (25.39)	270 (10.63)	175 (6.89)	210 (8.27)	242 (9.53)	195 (7.68)	205 (8.07)	480 (18.90)	315 (12.40)	10.6
4BD24-0FA0	8.2	F	3	650 (25.59)	395 (15.55)	315 (12.40)	350 (13.78)	382 (15.04)	335 (13.19)	270 (10.63)	510 (20.08)	435 (17.13)	16.7
4BE14-5CA0	120	C	3	285 (11.22)	185 (7.28)	150 (5.91)	185 (7.28)	217 (8.54)	170 (6.69)	145 (5.71)	200 (7.87)	230 (9.06)	3.8
4BE16-5CA0	82	C	3	285 (11.22)	185 (7.28)	150 (5.91)	185 (7.28)	217 (8.54)	170 (6.69)	145 (5.71)	200 (7.87)	230 (9.06)	3.8
4BE21-3DA0	39	D	3	515 (20.28)	270 (10.63)	175 (6.89)	210 (8.27)	242 (9.53)	195 (7.68)	205 (8.07)	350 (13.78)	315 (12.40)	7.4
4BE21-8EA0	27	E	3	645 (25.39)	270 (10.63)	175 (6.89)	210 (8.27)	242 (9.53)	195 (7.68)	205 (8.07)	480 (18.90)	315 (12.40)	10.6
4BE24-2FA0	12	F	3	650 (25.59)	395 (15.55)	315 (12.40)	350 (13.78)	382 (15.04)	335 (13.19)	270 (10.63)	510 (20.08)	435 (17.13)	16.7

Brake resistors for inverters of frame sizes **A** to **F**

All dimensions in mm (values in brackets are in inches)

MICROMASTER 440

Notes

4



MICROMASTER 420/430/440

Appendix



A/2	Environment, resources and recycling
A/2	Certificates
A/4	Compliance with standards
A/6	Drive ES engineering system
A/7	Demonstration case
A/7	Standard conversion factors: metric to US units
A/8	Training
A/9	Overview of SIMATIC ET 200S FC/ ET 200pro FC
A/11	Overview of SINAMICS G110, G120, G120D
A/14	Overview of IEC squirrel-cage motors
A/17	Overview of MICROMASTER 411 and COMBIMASTER 411
A/18	Overview of NEMA motors
A/19	Siemens contacts worldwide
A/20	Online services
A/21	Service & Support
A/22	Subject index
A/23	Order No. index Notes on ordering
A/24	Conditions of sale and delivery Export regulations

MICROMASTER 420/430/440

Appendix

Environment, resources and recycling

Siemens AG feels a responsibility to play a role in protecting our environment and saving our valuable natural resources. This is true for both our production and our products.

Even during development, we consider any possible environmental impact of future products/systems. Our aim is to prevent harmful environmental effects or at least to reduce them to an absolute minimum – beyond present regulations and legislation.

The most important activities for protecting our environment are as follows:

- We are constantly endeavoring to reduce the environmental impact of our products as well as their consumption of energy and resources over and above the statutory environmental protection regulations.
- We take every possible step to prevent damage to the environment.
- Environmental impact is assessed and considered at the earliest possible stage of product and process planning.

- Our optimized environmental management strategy ensures that our environmental policy is put into practice effectively. The necessary technical and organizational procedures are reviewed at regular intervals and continuously updated.
- An awareness for environmental problems is expected of all our employees. Establishing and furthering a sense of responsibility for the environment on all levels represents a permanent challenge for the corporate management.
- We urge our business partners to act according to the same environmental principles as ourselves. We cooperate with the responsible public authorities.
- We inform interested members of the public about the consequences of our corporate policies for the environment as well as our achievements to the benefit of the environment.
- Our complete documentation is printed on chlorine-free bleached paper.

Certificates



Certificates (continued)

SIEMENS

EG-Konformitätserklärung
664.20001.21

Hersteller: **Siemens AG
Automation and Drives
Standard Drives**

Anschrift: **Frauenauracherstr. 80
91056 Erlangen
Germany**

Produktbezeichnung: **MICROMASTER 410 / 6SE6410-.....-X*..
MICROMASTER 420 / 6SE6420-.....-X*..
MICROMASTER 430 / 6SE6430-.....-X*..
MICROMASTER 440 / 6SE6440-.....-X*..

* Baugrößen A bis G**

Das bezeichnete Produkt stimmt mit den Vorschriften folgender Europäischer Richtlinie überein:

73/23/EWG Richtlinie des Rates zur Angleichung der Rechtsvorschriften der Mitgliedstaaten betreffend elektrischer Betriebsmittel zur Verwendung innerhalb bestimmter Spannungsgrenzen, geändert durch RL 93/68/EWG des Rates

Die Übereinstimmung mit den Vorschriften dieser Richtlinie wird nachgewiesen durch die Einhaltung folgender Normen:

EN 61800-5-1: 2003¹⁾ EN 60204-1: 1998

¹⁾ Abweichungen zu den Forderungen der EN 61800-5-1 sind in einem technischen Bericht zur Risikobewertung dokumentiert.

Das bezeichnete Produkt ist zum Einbau in eine andere Maschine bestimmt. Die Inbetriebnahme ist solange untersagt, bis die Konformität des Endproduktes mit der Richtlinie 98/37/EG festgestellt ist.

Ereitausgabe: 30.10.2002
Erlangen, 31.07.2006

G. Bok
Head of Research and Development Drives & Motors

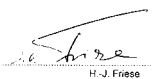
H.-J. Friese
Head of Quality Management

Diese Erklärung bescheinigt die Übereinstimmung mit den genannten Richtlinien, ist jedoch keine Beschaffenheits- oder Haltbarkeitsgarantie nach §443 BGB. Die Sicherheitsanweise der mitgelieferten Produktdokumentation sind zu beachten.

Legend for EC declaration of conformity:

The named product is in conformity with the requirements of the following European Directive:

73/23/EEC Council Directive on the approximation of the laws of the Member States relating to electrical equipment for use within certain voltage limits, amended by Council Directive RL 93/68/EEC

Conformity with the requirements of this Directive is testified by adherence to the following standards:

EN 61800-5-1: 2003¹⁾

The named product is intended for fitting in another machine. Commissioning is prohibited until such time as the end product has been proved to conform to the provisions of Directive 98/37/EC. This declaration certifies compliance with the Directives named above, but does not guarantee any specific properties or durability according to §443 BGB. The safety information and instructions in the supplied product documentation must be carefully observed.

1) Deviations to the requirements listed in EN 61800-5-1 must be documented in a technical report on the risk assessment.

MICROMASTER 420/430/440

Appendix

Compliance with standards

CE marking



The MICROMASTER inverters meet the requirements of the Low-Voltage Directive 73/23/EEC.

Low-voltage directive

The inverters comply with the following standards listed in the Official Journal of the European Communities:

• EN 60 204

Safety of machinery, electrical equipment of machines

• EN 61 800-5-1

Electrical power drive systems with variable speed – Part 5-1: Requirements regarding safety - electrical, thermal and energy requirements

Machine directive

The inverters are suitable for installation in machines. Compliance with the machine directive 89/392/EEC requires a separate certificate of conformity. This must be furnished by the plant constructor or the installer of the machine.

EMC directive

• EN 61 800-3

Variable-speed electric drives Part 3: EMC product standard including special test procedure.

The new EMC product standard EN 61 800-3 applies to electrical drive systems as of July 1, 2005. The transition period for the preceding standard EN 61 800-3/A11 dated February 2001 ends on October 1, 2007. The following explanations apply to frequency inverters of the 6SE6 series from Siemens:

- The EMC product standard EN 61 800-3 does not apply directly to a frequency inverter but to a PDS (Power Drive System), which comprises the complete circuitry, motor and cables in addition to the inverter.

- As a rule, frequency inverters are only supplied to qualified technical specialists for installation in machines or plants. A frequency inverter must therefore only be considered as a component which, as such, is not subject to the EMC product standard EN 61 800-3. However, the inverter's instruction manual specifies the conditions under which the product standard can be complied with if the frequency inverter is expanded to become a PDS. For a PDS, the EMC directive in the EU is complied with through observance of the product standard EN 61 800-3 for variable-speed electrical drive systems. The frequency inverters on their own do not generally require marking according to the EMC directive.

- The new EN 61 800-3 of July 2005 no longer distinguishes between "general availability" and "restricted availability". Instead, different categories, namely C1 to C4, are defined according to the environment of the PDS at the place of use:

– Category C1:

Drive systems for rated voltages of < 1000 V for use in the first environment

– Category C2:

Fixed-location drive systems which are not connected by means of plug-in devices, for rated voltages of < 1000 V. If used in the first environment, installation and start-up may only be carried out by qualified EMC personnel. Warning information must be provided.

– Category C3:

Drive systems for rated voltages of < 1000 V, solely for use in the second environment. Warning information must be provided.

– Category C4:

Drive systems for rated voltages of \geq 1000 V or for rated currents of \geq 400 A or for use in complex systems in the second environment. An EMC plan must be drawn up.

- In the EMC product standard EN 61 800-3, limits for conducted interference voltages and radiated interference are also indicated for the so-called "second environment" (= industrial power supply systems which do not supply households). These limits are lower than the limits of filter class A according to EN 55 011. The use of unfiltered inverters in an industrial environment is permissible provided they are part of a system that is equipped with line filters on the higher-level infeed side.
- With MICROMASTER, power drive systems (PDS) which comply with EMC product standard EN 61 800-3 can be installed (see the installation instructions in the product documentation). The table entitled "Overview of MICROMASTER components and PDS categories" and the MICROMASTER ordering documents show which components the respective PDS installation supports directly.
- In general, a distinction must be made between the product standards for electrical drive systems (PDS) of the EN 61 800 series of standards (of which Part 3 covers EMC topics) and the product standards for devices/systems/machines etc. This will probably not result in any changes in the practical use of frequency inverters. Since frequency inverters are always part of a PDS and the latter is part of a machine, the manufacturer of the machine must observe various standards depending on the type of machine and the environment, e.g. EN 61 000-3-2 for power supply harmonics and EN 55 011 for radio interference. The PDS product standard alone is therefore inadequate or irrelevant.
- With regard to compliance with limits for power supply harmonics, the EMC product standard EN 61 800-3 for PDS refers to compliance with the EN 61 000-3-2 and EN 61 000-3-12 standards.
- Irrespective of configuration with MICROMASTER and its components, the machine builder can also modify the machines in other ways in order to comply with the EMC directive of the EU. As a rule, the EMC directive of the EU is observed through compliance with the EMC product standards applicable to the machine. If they are not available, the generic standards such as DIN EN 61 000-x-x can be used instead. What is important is that the conducted interference and the radiated interference voltages at the power-supply connection point and outside the machine remain below the corresponding limits. What technical means are used to ensure this is not prescribed.

Overview of MICROMASTER components and PDS categories

First environment (residential, commercial)	Category C1 Unfiltered devices plus external Class B filter with low leakage currents	Second environment (industrial)	
	Category C2 Devices with an integrated Class B filter or devices with an integrated Class A filter plus external supplementary filter Class B or devices with an integrated Class A filter plus warning information or unfiltered devices plus external Class A filter plus warning information		Devices with an integrated Class B filter or devices with an integrated Class A filter plus external supplementary filter Class B or devices with an integrated Class A filter or unfiltered devices plus external Class A filter Note: The requirements of EN 61 800-3 are considerably exceeded if Class B filters are used.
	Category C3 Devices with integrated Class A filter or unfiltered devices plus external Class A filter Warning information is necessary. Note: The requirements of EN 61 800-3 are considerably exceeded if Class A filters are used.		
	Category C4 Unfiltered devices plus external Class A filter An EMC plan must be drawn up. Note: The requirements of EN 61 800-3 are considerably exceeded if Class A filters are used.		

Electromagnetic compatibility

No inadmissible electromagnetic emissions occur if the installation instructions specific to the product are correctly observed.

The table below lists the results of measurements relating to the emissions and immunity to interference of MICROMASTER inverters.

The inverters were installed with shielded motor cables and shielded control cables in accordance with the directives.

EMC phenomenon Standard/test	Relevant criteria	Limit value
Emitted interference EN 61 800-3	Conducted via mains cable	150 kHz to 30 MHz Unfiltered devices, not tested. All devices with an internal/external filter: Depending on the type of filter and on the envisaged PDS installation: Category C1: Limit value complies with EN 55 011, Class B Category C2: Limit value complies with EN 55 011, Class A, Group 1. In addition, all devices with an internal/external filter comply with the limit value for category C3 installations. Limit value complies with EN 55 011, Class A, Group 2.
	Emitted by the drive	30 MHz to 1 GHz All devices. Limit value complies with EN 55 011, Class A, Group 1.
ESD immunity EN 61 000-4-2	ESD through air discharge ESD through contact discharge	Test severity level 3 Test severity level 3 8 kV 6 kV
Immunity to electrical fields EN 61 000-4-3	Electrical field applied to unit	Test severity level 3 80 MHz to 1 GHz 10 V/m
Immunity to burst interference EN 61 000-4-4	Applied to all cable terminations	Test severity level 4 4 kV
Surge immunity EN 61 000-4-5	Applied to mains cables	Test severity level 3 2 kV
Immunity to RFI emissions, conducted EN 61 000-4-6	Applied to mains, motor and control cables	Test severity level 3 0.15 MHz to 80 MHz 80 % AM (1 kHz) 10 V

UL listing



® and c® listed power conversion equipment of ® category NMMS, in accordance with UL508C.

® list number E121068 and E192450

For use in environments with pollution degree 2.

Also refer to the Internet at <http://www.ul.com>



MICROMASTER 420/430/440

Appendix

Drive ES engineering system

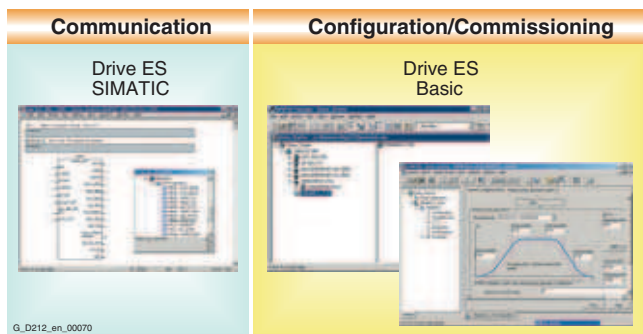

Drive ES is the engineering system used to integrate Siemens drive technology into the SIMATIC automation world easily, efficiently and cost-effectively in terms of communication, configuration and data management. The STEP 7 Manager user interface provides the basis for this procedure.

Various software packages are available for MICROMASTER:

- **Drive ES Basic** for first-time users of the world of Totally Integrated Automation and the option for routing beyond network limits and the use of the SIMATIC teleservice.

Drive ES Basic is the basic software program for setting the parameters of all drives online and offline.

Drive ES Basic processes the automated system and drives on the interface of the SIMATIC Manager. Drive ES Basic is the starting point for common data archiving for complete projects and for extending the use of the SIMATIC teleservice to drives. Drive ES Basic provides the engineering tools for the new motion control functions – peer-to-peer data traffic, equidistance and isochronous operation with PROFIBUS DP.

- **Drive ES SIMATIC**

Simply parameterize the STEP 7 communication instead of programming. In order to use Drive ES SIMATIC STEP 7 must be installed. It features a SIMATIC function block library, thereby making the programming of the PROFIBUS interface in the SIMATIC-CPU for the drives easy and secure.

There is no need for separate, time-consuming programming of the data exchange between the SIMATIC-CPU and the drive.

All Drive ES users need to remember is:

Copy – Modify – Load – Finished.

Customized, **fully-developed function blocks** are copied from the library into user-specific projects. Frequently-used functions are set to run in program format:

- Read out complete diagnostics buffer automatically from the drive
- Complete parameter sets are automatically downloaded into the drive from the SIMATIC CPU – e.g. when a device has to be replaced

– Part parameter sets (e.g. for recipe and product change) are automatically downloaded into the drive from the SIMATIC-CPU

– Complete parameterization or part parameter sets are uploaded from the drive into the SIMATIC-CPU, i.e. updated.

- **Drive ES PCS 7**

integrates drives with the PROFIBUS interface into the SIMATIC PCS 7 process control system.

Drive ES PCS 7 can only be used with SIMATIC PCS 7 Version 5.2 and higher.

Drive ES PCS 7 provides a function block library with function blocks for the drives and the corresponding faceplates for the operator station, which enables the drives to be operated from the PCS 7 process control system.

For further information please visit us on the Internet at:

<http://www.siemens.com/drivesolutions>

Selection and ordering data

Description	Software	Order No.
Drive ES Basic V 5.4 • Configuration software for the integration of drives into Totally Integrated Automation	• Requirement: STEP 7 V 5.3 and higher, SP3	Single license 6SW1700-5JA00-4AA0
	• Supply format: on CD-ROM de, en, fr, es, it with electronic documentation	Multi-user license, 60 pieces 6SW1700-5JA00-4AA1
		Update service for single-user license 6SW1700-0JA00-0AB2
		Update service for multi-user license 6SW1700-0JA00-1AB2
		Upgrade from V 5.x to V 5.4 6SW1700-5JA00-4AA4
Drive ES SIMATIC V 5.4 • Function block library for SIMATIC for the parameterization of communication with the drives	• Requirement: STEP 7 V 5.3 and higher, SP3	Single-user license incl. 1 x runtime license 6SW1700-5JC00-4AA0
	• Supply format: on CD-ROM de, en, fr, es, it with electronic documentation	Runtime license 6SW1700-5JC00-1AC0
		Update service for single-user license 6SW1700-0JC00-0AB2
		Upgrade from V 5.x to V 5.4 6SW1700-5JC00-4AA4
Drive ES PCS 7 V 6.1 • Function block library for PCS 7 for the integration of drives	• Requirement: PCS 7 V 6.1	Single-user license incl. 1 x runtime license 6SW1700-6JD00-1AA0
	• Supply format: on CD-ROM de, en, fr, es, it with electronic documentation	Runtime license 6SW1700-5JD00-1AC0
		Update service for single-user license 6SW1700-0JD00-0AB2
		Upgrade from V 5.x to V 6.1 6SW1700-6JD00-1AA4

Demonstration case**SIDEMO demonstration case system**

The SIDEMO range of modular demonstration case systems also includes cases for the MICROMASTER inverters.

The MICROMASTER demonstration cases can be operated on 230 V supplies on their own or together with other demonstration systems such as LOGO!, SIMATIC S7-200, SITOP DC-UPS.

The demonstration systems are fitted in dark blue transport cases (400 x 300 x 210 mm). The transport cases can be stacked.

If the MICROMASTER 420/440 demonstration case is expanded with a PROFIBUS module (not included in scope of supply of the case), it is also possible to demonstrate incorporation into TIA in combination with the SIMATIC S7-300 Compact and Touchpanel TP170B demonstration systems.



SIDEMO demonstration case	Order No.	Weight, approx. kg
MICROMASTER 420 • including BOP operator panel	6AG1062-1AA02-0AA0	10
MICROMASTER 440 • including BOP operator panel	6AG1062-1AA02-1AA1	10
MICROMASTER 440 • including BOP operator panel • the motor is equipped with a load unit	6AG1062-1AA06-0AA0	10
MICROMASTER 440 • including BOP operator panel and pulse encoder evaluation module • the motor is equipped with an encoder and a load unit	6AG1062-1AA07-0AA0	10

Further information, e.g. **110 V versions**, is available on the Internet at: <http://www.siemens.de/sidemo>

Standard conversion factors: metric to US units

Unit	US to metric standard units	Metric to US standard units
Length	1 in. = 25.40 mm	1 mm = 0.03937 in.
	1 ft. = 30.48 cm	1 cm = 0.39370 in.
	1 yd. = 0.91 m	1 m = 3.28084 ft.
	1 mi. = 1.61 km	1 km = 0.62137 mi.
Temperature	°C = 5/9 (°F - 32)	°F = (9 x °C)/5 + 32
Weight	1 lbs = 0.454 kg	1 kg = 2.205 lbs
Torque	1 lb.ft. = 1.356 Nm	1 Nm = 0.738 lb.ft.
Power	1 hp = 0.746 kW	1 kW = 1.341 hp

Note:

For kW and hp specifications in the Selection and Ordering tables, we do not use calculated hp values but the corresponding standardized hp motor ratings.

MICROMASTER 420/430/440

Appendix

Faster and more applicable know-how: Hands-on training from the manufacturer

SITRAIN® – the Siemens Training for Automation and Industrial Solutions – provides you with comprehensive support in solving your tasks.

Training by the market leader in automation and plant engineering enables you to make independent decisions with confidence. Especially where the optimum and efficient use of products and plants are concerned. You can eliminate deficiencies in existing plants, and exclude expensive faulty planning right from the beginning.



First-class know-how directly pays for itself: In shorter startup times, high-quality end products, faster troubleshooting and reduced downtimes. In other words, increased profits and lower costs.

Achieve more with SITRAIN

- Shorter times for startup, maintenance and servicing
- Optimized production operations
- Reliable configuration and startup
- Minimization of plant downtimes
- Flexible plant adaptation to market requirements
- Compliance with quality standards in production
- Increased employee satisfaction and motivation
- Shorter familiarization times following changes in technology and staff

Contact

Visit our site on the Internet at:

www.siemens.com/sitrain

or let us advise you personally. You can request our latest training catalog from:

SITRAIN Customer Support Germany:

Phone: +49 (0)1805 / 23 56 11
(0.14 €/min from the German landline network)

Fax: +49 (0)1805 / 23 56 12

SITRAIN highlights

Top trainers

Our trainers are skilled teachers with direct practical experience. Course developers have close contact with product development, and directly pass on their knowledge to the trainers.

Practical experience

The practical experience of our trainers enables them to teach theory effectively. But since theory can be pretty drab, we attach great importance to practical exercises which can comprise up to half of the course time. You can therefore immediately implement your new knowledge in practice. We train you on state-of-the-art methodically/didactically designed training equipment. This training approach will give you all the confidence you need.

Wide variety

With a total of about 300 local attendance courses, we train the complete range of A&D products as well as interaction of the products in systems. Telecourses, teach-yourself software and seminars with a presenter on the Web supplement our classic range of courses.

Tailor-made training

We are only a short distance away. You can find us at more than 50 locations in Germany, and in 62 countries worldwide. You wish to have individual training instead of one of our 300 courses? Our solution: We will provide a program tailored exactly to your personal requirements. Training can be carried out in our Training Centers or at your company.

The right mixture: Blended learning

“Blended learning” means a combination of various training media and sequences. For example, a local attendance course in a Training Center can be optimally supplemented by a teach-yourself program as preparation or follow-up. Additional effect: Reduced traveling costs and periods of absence.



Overview of frequency inverters/converters for SIMATIC ET 200 distributed I/O

Frequency inverters are available for the SIMATIC ET 200 distributed I/O that are fully system-integrated modules. Inverters are available for the finely modular SIMATIC ET 200S FC system to the IP20 degree of protection as well as for the cabinet-free SIMATIC ET 200pro FC system to the IP65 degree of protection.

With a broad range of possibilities, the frequency inverters expand the functional scope of the modular modules that are available in both systems (e.g. inputs and outputs, technology modules, direct and soft starters). With suitable interface modules, connection to PROFIBUS and PROFINET is possible via the ET 200

system bus as well as integration of PLC functionality into the system. Fail-safe frequency inverter functions can be activated locally or via PROFIsafe.

An overview of the features of the SIMATIC ET 200S FC frequency inverter series is given in the table below.

The complete product spectrum including ordering data, technical data and explanations can be found in Catalog IK PI "Industrial Communication for Automation and Drives" and on the Internet at

<http://www.siemens.com/et200s-fc>

SIMATIC ET 200S FC	
Main features	<ul style="list-style-type: none"> • Complete embedding of a frequency inverter into a distributed I/O system to IP20 degree of protection • Easy assembly and low susceptibility to errors thanks to self-assembling energy and communications bus • Space-saving assembly thanks to compact dimensions and common protection • Fast, tool-free replacement of the frequency inverter for a servicing requirement (hot swapping) • Frequency control (V/f), vector control with and without encoders • Line-commutated regenerative feedback by power electronics of the latest generation • Modular structure with Control Unit (closed-loop control module) and Power Module (power section) • Frequency inverter variant with integrated, autonomous, fail-safe functions without the need for complex external wiring
Rated outputs	0.75 kW, 2.2 kW, 4.0 kW
Input voltage	3 AC 380 ... 480 V \pm 10%
Overall width	Control Unit + Power Module up to 0.75 kW: 80 mm, otherwise 145 mm
Mains frequency	47 ... 63 Hz
Overload capability	<ul style="list-style-type: none"> • Overload current 1.5 \times rated output current (i.e. 150% overload) over 60 s, cycle time 300 s • Overload current 2 \times rated output current (i.e. 200% overload) over 3 s, cycle time 300 s
Output frequency	0 ... 650 Hz
Pulse frequency	8 kHz (standard), 2 ... 16 kHz (in steps of 2 kHz)
Frequency bands that can be skipped	1, programmable
Efficiency	\geq 96%
Interfaces	<ul style="list-style-type: none"> • Connection to PROFIBUS via IM151 interface module • Connection to PROFINET via IM151-3PN interface module • Integration of PLC functionality through IM151 CPU and IM151-7 F CPU interface modules • RS232 interface with USS protocol for commissioning on the PC with the STARTER commissioning software • Slot for an optional Micro Memory Card for uploading or downloading parameter settings • PTC/KTY84 interface for motor monitoring • Speed sensor interface (Sub-D connector) for unipolar HTL incremental encoder • Activation of the integrated safety functions over PROFIsafe (using the PM-D F PROFIsafe Power Module) or terminals (using the Safety Local Power Module PM-D F X1)
Standards conformance	UL, cUL, CE and c-tick, Low-Voltage Directive 73/23/EEC, EMC Directive 89/336/EEC
Functional safety	<p>Closed-loop control module with integral safety functions to Category 3 of EN 954-1 and SIL 2 of IEC 61508:</p> <ul style="list-style-type: none"> • Safety torque off • Safely limited speed • Safe stop 1 <p>The safety functions "Safely limited speed" and "Safe stop 1" are certified for encoderless asynchronous motors. These safety functions are not approved for pull-through loads as in the case of lifting gear and winders</p>
Degree of protection	IP20

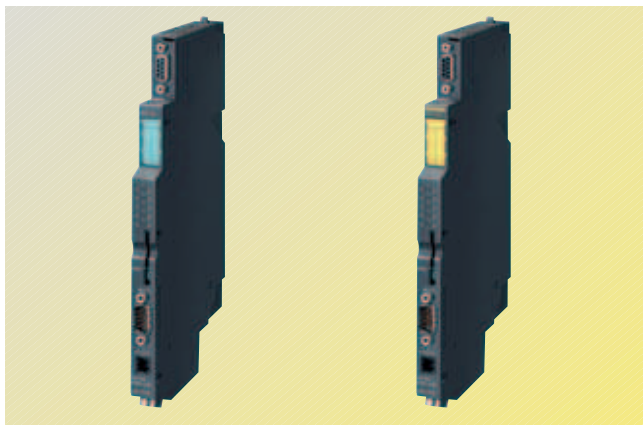

SIMATIC ET 200S FC
Control Units



SIMATIC ET 200S FC
Power Modules

MICROMASTER 420/430/440

Appendix

Overview of frequency inverters/converters for SIMATIC ET 200 distributed I/O (continued)

Frequency inverters are available for the SIMATIC ET 200 distributed I/O that are fully system-integrated modules. Inverters are available for the finely modular SIMATIC ET 200S FC system to the IP20 degree of protection as well as for the cabinet-free SIMATIC ET 200pro FC system to the IP65 degree of protection.

With a broad range of possibilities, the frequency inverters expand the functional scope of the modular modules that are available in both systems (e.g. inputs and outputs, technology modules, direct and soft starters). With suitable interface modules, connection to PROFIBUS and PROFINET is possible via the ET 200

system bus as well as integration of PLC functionality into the system. Fail-safe frequency inverter functions can be activated locally or via PROFIsafe.

An overview of the features of the SIMATIC ET 200pro FC frequency inverter series is given in the table below.

The complete product spectrum including ordering data, technical data and explanations can be found in Catalog IK PI "Industrial Communication for Automation and Drives" (SIMATIC ET 200pro FC will be available soon) and on the Internet at

<http://www.siemens.com/et200pro-fc>

SIMATIC ET 200pro FC	
Main features	<ul style="list-style-type: none"> • Complete embedding of a frequency inverter into a distributed I/O system to IP65 degree of protection • Easy assembly and low susceptibility to errors thanks to self-assembling energy and communications bus • Fast replacement of the frequency inverter during servicing without interruption of the bus communication to other modules within the SIMATIC ET 200pro FC • Frequency control (V/f), vector control without encoders • Line-commutated regenerative feedback by power electronics of the latest generation • Frequency inverter variant with integrated, autonomous, fail-safe functions without the need for complex external wiring
Rated outputs	1.1 kW (at 0 ... 55 °C ambient temperature) 1.5 kW (at 0 ... 45 °C ambient temperature)
Input voltage	3 AC 380 ... 480 V ± 10%
Overall width	155 mm
Mains frequency	47 ... 63 Hz
Overload capability	<ul style="list-style-type: none"> • Overload current 1.5 × rated output current (i.e. 150% overload) over 60 s, cycle time 300 s • Overload current 2 × rated output current (i.e. 200% overload) over 3 s, cycle time 300 s
Output frequency	0 ... 650 Hz
Pulse frequency	4 kHz (standard) 2 ... 16 kHz (in steps of 2 kHz)
Frequency bands that can be skipped	1, programmable
Efficiency	≥ 96%
Interfaces	<ul style="list-style-type: none"> • Connection to PROFIBUS through IM154-1 and IM154-2 interface modules • Available soon connection to PROFINET over IM154-4PN interface modules and connection to IM154-8 CPU interface modules • Optical interface with USS protocol for fiber-optic RS232 connecting cable • Control signal for 180 V DC electromagnetic motor brake • Slot for an optional memory card (MMC) for uploading or downloading parameter settings • PTC/KTY84 interface for motor temperature monitoring • Activation of the integrated safety functions through the Safety Local Isolator Module F RSM or through F-Switch PROFIsafe
Standards conformance	UL, cUL, CE, Low-Voltage Directive 73/23/EEC, EMC Directive 89/336/EEC
Functional safety	Variant with integral safety functions to Category 3 of EN 954-1 and SIL 2 of IEC 61508: <ul style="list-style-type: none"> • Safety torque off • Safely limited speed • Safe stop 1 The safety functions "Safely limited speed" and "Safe stop 1" are certified for encoderless asynchronous motors. These safety functions are not approved for pull-through loads as in the case of lifting gear and winders
Degree of protection	IP20



SIMATIC ET 200pro FC
Standard frequency inverter



SIMATIC ET 200pro FC Failsafe
Frequency inverter with integrated safety functions

Overview of SINAMICS G110 inverter chassis units

The SINAMICS G110 inverter chassis unit is a versatile drive. The table provides an overview of the features of this

product. The complete range of products together with ordering data, technical data and explanations are indica-

ted in the D 11.1 Catalog "SINAMICS G110/SINAMICS G120 Inverter Chassis Units and SINAMICS G120D

Distributed Frequency Inverters" and in the Internet under: <http://www.siemens.com/sinamics-g110>

SINAMICS G110	
Main features	As " a versatile drive for small outputs ", the frequency inverter of the SINAMICS G110 inverter chassis units can be used for a wide range of industrial drive applications with variable speeds. The especially compact SINAMICS G110 inverter works with voltage-frequency control (V/f) and is the ideal frequency inverter in the lower output and performance range of the SINAMICS family of products. The inverter is available in three frames for connection to single-phase power supply systems.
Electrical data	
Supply voltages, output range	1 AC 200 V ... 240 V, $\pm 10\%$; 0.12 kW ... 3.0 kW
Network types	IT, TN, TT
Mains frequency	50/60 Hz
Output frequency	0 Hz ... 650 Hz
Control method	V/f control, linear ($M \sim n$) V/f control, quadratic ($M \sim n^2$) V/f control, programmable
Fixed frequencies	3, programmable
Skip frequency ranges	1, programmable
Digital inputs	3 programmable digital inputs 24 V DC
Analog input (for the analog version)	1 analog input for setpoints from 0 V to 10 V, scalable or usable as 4th digital input
Digital output	1 digital output 24 V DC
Communication interface (for USS version)	RS485 serial interface for operation with USS protocol
Software functions	<ul style="list-style-type: none"> • Automatic restart after interruption of operation due to supply failure • Jerk-free connection of inverter to rotating motor • Programmable ramp-up/ramp-down times • Ramp rounding
Functions	
Protection functions	<ul style="list-style-type: none"> • Undervoltage • Overvoltage • Earth fault • Short-circuit • Stall prevention • I^2t motor thermal protection • Inverter overtemperature • Motor overtemperature
Connectable motors	Asynchronous motors
Mechanical data	
Degree of protection	IP20
Type of cooling for ≤ 0.75 kW inverters > 0.75 kW inverters	Ribbed heat sink with convection cooling; version with flat heat sink also available Internal air cooling (integrated fan)
Standards	
Standards complied with	CE, UL, cUL, c-tick



SINAMICS G110 inverter chassis units

MICROMASTER 420/430/440

Appendix

Overview of SINAMICS G120 inverter chassis units

The SINAMICS G120 inverter chassis unit is a modular drive. The table provides an overview of the features of this product. The complete range

of products together with ordering data, technical data and explanations are indicated in the D 11.1 Catalog "SINAMICS G110/SINAMICS

G120 Inverter Chassis Units and SINAMICS G120D Distributed Frequency Inverters" and in the Internet under:

<http://www.siemens.com/sinamics-g120>

SINAMICS G120	
Main features	As "a modular single drive for low and medium outputs" , the frequency inverter of the SINAMICS G120 inverter chassis units can be used for a wide range of industrial drive applications. The SINAMICS G120 frequency inverter distinguishes itself through its modular design (Power Module and Control Unit), and the globally unique integration of numerous innovative functions in safety technology and regenerative feedback into the line supply. There are extensive system components available in the range from 0.37 to 90 kW. This means that the drive units are suitable for a multitude of drive applications.
Electrical data	
Supply voltages, output range	3 AC 380 V ... 480 V, ±10%; 0.37 kW ... 90 kW
Network types	IT, TN, TT
Mains frequency	47 ... 63 Hz
Output frequency	0 Hz ... 650 Hz
Control method	V/f control, linear ($M \sim n$) V/f control, quadratic ($M \sim n^2$) and parameterizable sensorless vector control, vector control with encoder (closed control loop) Torque control
Fixed frequencies	16, programmable
Digital inputs	up to 9 digital inputs, depending on the Control Unit 24 V DC
Analog input (for the analog version)	up to 2 analog inputs (0 V to 10 V)
Digital output	3 digital inputs
Communication interface	RS485/USS; PROFIBUS; PROFINET
Functions	
Software functions	<ul style="list-style-type: none"> • Programmable ramp-up times 0 ... 650 s, ramp rounding • Automatic restart after interruption of operation due to supply failure • Flying restart • Signals are locally pre-processed using free function blocks • 3 selectable motor data sets • High-quality internal PID controller for simple process control • Positioning ramp down • Kinetic buffering
Protection functions	<ul style="list-style-type: none"> • Motor temperature (PTC/KTY, P_t) • Power unit and load cycle monitoring • Overvoltage and undervoltage • Earth fault • Stall prevention • System protection functions
Safety Integrated Functions	STO, SS1, SLS, SBC
Connectable motors	Asynchronous motors
Mechanical data	
Degree of protection	IP20
Cooling method	Innovative cooling concept; the power electronics are cooled by means of heat sinks with an external fan; open-loop and closed-loop control electronics are cooled by convection
Standards	
Standards complied with	CE, UL, cUL, c-tick, Safety Integrated IEC 61508/SIL 2



SINAMICS G120 inverter chassis units

Overview of SINAMICS G120D distributed frequency inverter

The SINAMICS G120D frequency inverter is a modular drive. The table provides an overview of the features of this product. The complete range

of products together with ordering data, technical data and explanations are indicated in the D 11.1 Catalog "SINAMICS G110/SINAMICS

G120 Inverter Chassis Units and SINAMICS G120D Distributed Frequency Inverters" and in the Internet under:

<http://www.siemens.com/sinamics-g120d>

SINAMICS G120D	
Main features	"The modular drive for low and medium outputs" – the SINAMICS G120D distributed frequency inverter can be especially used for sophisticated conveyor applications in industry as for many other high-performance applications. The SINAMICS G120 frequency inverter distinguishes itself through its modular design (Power Module and Control Unit) as well as through its extremely flat type of construction, an identical drilling template for all outputs and a high degree of safety. It offers safety functions that are unique in its class. It helps to save significant amounts of energy as a result of its line-commutated regenerative feedback capability. It goes without saying that the frequency inverter is also capable of communications.
Electrical data	
Supply voltages, output range	3 AC 380 V ... 480 V, ±10%; 0.75 kW ... 7.5 kW
Network types	IT, TN, TT
Mains frequency	47 ... 63 Hz
Output frequency	0 Hz ... 650 Hz
Control method	V/f control, linear ($M \sim n$) V/f control, quadratic ($M \sim n^2$) and parameterizable sensorless vector control, vector control with encoder (closed control loop) Torque control
Fixed frequencies	16, programmable
Digital inputs	up to 6 digital inputs, depending on the Control Unit 24 V DC
Analog input (for the analog version)	up to 2 analog inputs (0 V to 10 V)
Digital output	3 digital outputs
Communication interface	PROFIBUS; PROFINET
Functions	
Software functions	<ul style="list-style-type: none"> • Programmable ramp-up times 0 ... 650 s, ramp rounding • Automatic restart after interruption of operation due to supply failure • Flying restart • Signals are locally pre-processed using free function blocks • 3 selectable motor data sets • High-quality internal PID controller for simple process control • Positioning ramp down • Kinetic buffering
Protection functions	<ul style="list-style-type: none"> • Motor temperature (PTC/KTY, P_t) • Power unit and load cycle monitoring • Overvoltage and undervoltage • Earth fault • Stall prevention • System protection functions
Safety Integrated Functions	STO, SS1, SLS
Connectable motors	Asynchronous motors
Mechanical data	
Degree of protection	IP65
Cooling method	Convection cooling, for higher outputs with fan
Standards	
Standards complied with	CE, UL, cUL, c-tick, Safety Integrated IEC 61508/SIL 2



SINAMICS G120D distributed frequency inverter

MICROMASTER 420/430/440

Appendix

Overview of IEC squirrel-cage motors

With an output range from 0.06 to 1250 kW, low-voltage motors are available for the widest range of requirements and applications that are harmonized and coordinated with the MICROMASTER and SINAMICS frequency inverters.

In addition to energy-saving motors and explosion-proof motors, there are also sector and customer-specific motors such as smoke extraction motors.

The table shows an overview of the technical features of these motors. You will find the available product range with ordering data, technical data and detailed explanations in Catalog D 81.1 "Low-Voltage

Motors – IEC Squirrel-Cage Motors – Frame Sizes 56 to 450" and

in the Internet under:
<http://www.siemens.com/motors>

Versions	IEC Squirrel-Cage Motors		
	Energy-saving motors		Smoke extraction motors
	Aluminum housing	Gray cast housing	Temp.-time classes F200/F300/F400
Rated power	0.06 ... 45 kW	0.75 ... 1250 kW	0.37 ... 200 kW
Frame sizes	56 M to 225	100 L to 450	80 M to 315 L
Type of construction	All common types of construction	All common types of construction	All common types of construction
Speed	750 ... 3000 rpm	750 ... 3000 rpm	1000 ... 3000 rpm
Rated torque	0.3 ... 292 Nm	9.9 ... 10300 Nm	2.5 ... 1546 Nm
Rated voltages	All commonly used voltages	All commonly used voltages	230VΔ/400 VY, 500 VΔ, 400VΔ/690 VY, 500 VY
Designation	EFF1, EFF2	EFF1, EFF2	EFF1, EFF2
Degree of protection	IP55	IP55	IP55
Housing	Aluminum	Gray iron	Aluminum Gray iron
Cooling type	Surface-cooled	Surface-cooled	Surface-cooled
Temperature class	155 (F) utilized to 130 (B) / 155 (F)	155 (F) utilized to 130 (B) / 155 (F)	155 (F) utilized to 130 (B)
Approvals	CE, CCC, UL, CSA	CE, CCC, UL, CSA	CE
Approvals for marine propulsion drives	Below deck use: BV, DNV, GL, LR	Below deck use: BV, DNV, GL, LR	No
Explosion protection (incl. temp. class)	Ex nA II T3 (Zone 2), Dust-ex (Zone 21, 22)	Ex nA II T3 (Zone 2), Dust-ex (Zone 21, 22)	No



Examples, energy-saving motors



Example, smoke extraction motors

Overview of IEC squirrel-cage motors

Versions	IEC Squirrel-Cage Motors			
	Explosion-proof motors			
	Type of protection "e"	Type of protection "d"	Type of protection "n"	Dust explosion protection
Rated power	0.12 ... 165 kW	0.25 ... 950 kW	0.09 ... 1000 kW	0.06 ... 1000 kW
Frame sizes	63 M to 315 L	71 M to 450	63 M to 450	Zone 21: 56 M to 315 L Zone 22: 56 M to 450
Type of construction	All common types of construction	All common types of construction	All common types of construction	All common types of construction
Speed	1000 ... 3000 rpm	750 ... 3000 rpm	750 ... 3000 rpm	750 ... 3000 rpm
Rated torque	0.61 ... 1300 Nm	1 ... 8579 Nm	1 ... 8090 Nm	0.3 ... 8090 Nm
Rated voltages	All commonly used voltages	All commonly used voltages	All commonly used voltages	All commonly used voltages
Designation	See Catalog D 81.1	See Catalog D 81.1	Analog energy-saving motors EFF1/EFF2	Analog energy-saving motors EFF1/EFF2
Degree of protection	IP55, IP56 (non-heavy-sea), IP65	IP55, IP56 (non-heavy-sea)	IP55, IP56 (non-heavy-sea), IP65	Zone 21: IP65 Zone 22: IP55
Housing	FS 63 ... 160 L Aluminum FS 100 L ... 315 L Gray iron	FS 71 M ... 315 L Gray iron FS 355 ... 450 Steel	FS 63 M ... 160L Aluminum FS 100 L ... 450 Gray iron	FS 63 M ... 225 M Aluminum FS 100 L ... 450 Gray iron
Cooling type	Surface-cooled	Surface-cooled	Surface-cooled	Surface-cooled
Temperature class	155 (F) utilized to 130 (B) / 155 (F)	155 (F) utilized to 130 (B) (line operation) 155 (F) utilized to 155 (F) (frequency inverter operation)	155 (F) utilized to 130 (B)	155 (F) utilized to 130 (B)
Approvals	CE, CCC, GOST, ATEX	CE, CCC, GOST, ATEX, NEPSI	CE, CCC, GOST, ATEX, NEPSI	CE, CCC, GOST, ATEX
Approvals for marine propulsion drives	Below deck use: BV, DNV, GL, LR	Below deck use: BV, DNV, GL, LR	Below deck use: BV, DNV, GL, LR	Below deck use: BV, DNV, GL, LR
Explosion protection (incl. temp. class)	II 2G Ex e II T1-T3	II 2G Ex de IIC T1-T4	II 3G Ex nA II T3	Zone 21: II 2D Ex tD A21 IP65 T125 °C Zone 22: II 3D Ex tD A22 IP55 T125 °C

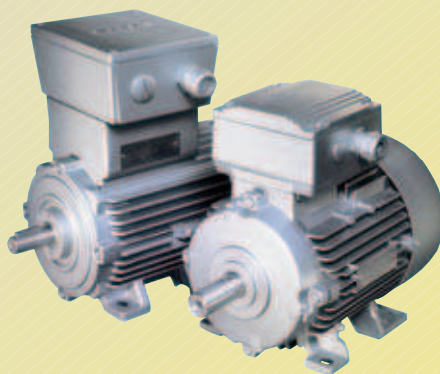

Examples, explosion-proof motors

MICROMASTER 420/430/440

Appendix

Overview of IEC squirrel-cage motors – new generation 1LE1

Increasing energy costs have resulted in greater emphasis on the power consumption of drive systems. It is extremely important to utilize the full potential for minimization here to secure competitiveness today and in the future. This is the reason that already today,

Siemens is developing a new generation of low-voltage motors. Innovative copper rotors create the best requisites for motors with high efficiencies. The new motors for EFF1 (High Efficiency) offer considerable energy savings and protect our environment.

The table shows an overview of the technical features of these motors. The presently available product range with ordering data, technical data and detailed explanations are provided in the new Catalog News D 81.1 N "Low-Voltage Motors – IEC Squirrel-Cage

Motors – New Generation 1LE1 – Frame Size 100 to 160" and

in the Internet under:
<http://www.siemens.com/motors>

IEC Squirrel-Cage Motors – new generation 1LE1	
Versions	Self-cooled energy-saving motors with: <ul style="list-style-type: none"> • Improved efficiency (EFF2) • High efficiency (EFF1) Self-cooled motors with increased output and: <ul style="list-style-type: none"> • Improved efficiency (EFF2) • High efficiency (EFF1) Forced-air-cooled motors without external fan and fan cover with: <ul style="list-style-type: none"> • Improved efficiency (EFF2) • High efficiency (EFF1)
Rated power	0.75 ... 22 kW
Frame sizes	100 L to 160 L
Type of construction	Without flange: IM B3, IM B6, IM B7, IM B8, IM V5 without protective cover, IM V6, IM V5 with protective cover With flange: IM B5, IM V1 without protective cover, IM V1 with protective cover, IM V3, IM B35 With standard flange: IM B14, IM V19, IM V18 without protective cover, IM V18 with protective cover, IM B34
Speed	750 ... 3000 rpm
Rated torque	9.9 ... 150 Nm
Rated voltages	All commonly used voltages
Designation	EU/CEMEP efficiency classification: EFF1: 2-, 4-pole, EFF2: 2-, 4-pole US Energy Policy Act EPACT: 2-, 4-, 6-pole (available soon)
Degree of protection	IP55 as standard
Housing	Aluminum
Cooling type	Self-cooled: Frame size 100 L to 160 L (IC 411), Forced-air cooled: Frame size 100 L to 160 L (IC 416)
Temperature class	Temperature class 155 (F), utilized to temperature class 130 (B)
Approvals	CE

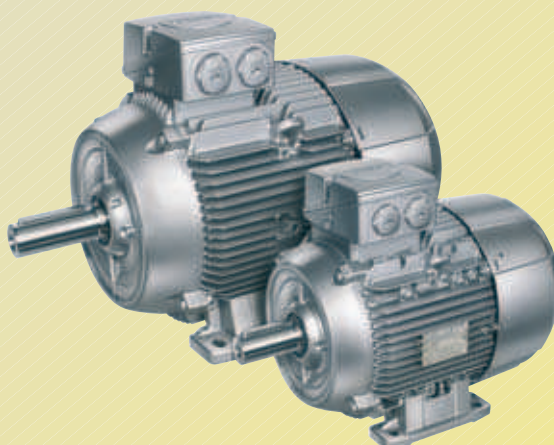

Examples, IEC squirrel-cage motors – new generation 1LE1, aluminum housing

Overview of distributed drive solutions – MICROMASTER 411 and COMBIMASTER 411 inverters

The MICROMASTER 411 and COMBIMASTER 411 inverters from Siemens are available as distributed drive solutions. The table provides an over-

view of the features of these products. The complete range of products together with ordering data, technical data and explanations are indicat-

ed in the Catalog DA 51.3 MICROMASTER 411 and COMBIMASTER 411. The latest information on MICROMASTER 411 and

COMBIMASTER 411 is available in the Internet under: <http://www.siemens.com/combimaster>

	MICROMASTER 411	COMBIMASTER 411
Main features	"The distributed inverter" for a wide range of drive applications – for simple individual applications from pumps and fans to multiple conveyor-belt drives in networked control systems.	
Output range	0.37 kW ... 3 kW	
Voltage range	3 AC 380 V ... 480 V	
Frame sizes/ unit sizes	CS B CS C	71 ... 100 90/100
Types of construction		IM B3 IM B5 IM V1 (without protective cover) IM V1 (with protective cover) IM B14 (with normal flange) IM B14 (with special flange) IM B35
Degree of protection	IP65	IP55
Other technical features	<ul style="list-style-type: none"> • V/f characteristic • Multipoint characteristic (programmable V/f characteristic) • FCC (flux current control) • Internal PI controller • 3 digital inputs • 1 analog input • 1 relay output • Compound braking for controlled rapid braking • ECOFAST versions with plug-in connectors for power-supply, communication interface and motor connections in order to enable fast and problem-free information exchange in applications where time is a critical factor. The ECOFAST versions are completely compatible with the ECOFAST technology systems. 	



Examples MICROMASTER 411



Examples COMBIMASTER 411

MICROMASTER 420/430/440

Appendix

Overview of NEMA motors

For compliance with the local specifications of the NAFTA markets (USA, Canada and Mexico), we manufacture low-voltage motors acc. to the NEMA standard for a wide range of different application areas.

This includes motors designed in accordance with the US act, EPACT (specified minimum efficiency levels), as well as motors with NEMA premium efficiency levels: Our NEMA motor series provide the highest operating reliability and maximum service life.

Designed and manufactured for rugged operation, our NEMA motors conquer even the harshest industrial conditions strictly in accordance with the ISO 9001 international quality standard; with maximum performance, reliability and efficiency.

You will find the complete range of products together with ordering data, technical data and explanations in Catalog D 81.2 U.S./Canada on the Internet at <http://www.sea.siemens.com/motors>

NEMA motors (NEMA = National Electrical Manufacturers Association)	
Frame size	NEMA frame size 56 ... 449
Output range	0.25 HP ... 500 HP
Number of poles	2/4/6/8
Voltages	3 AC 230/460/575 V
Frequency	60 Hz, 50 Hz on request
Type of construction	Foot-mounted, D flange, C flange, P flange
Casing	Cast-iron, aluminium or steel depending on the version
Cooling method	Surface-cooling or internal ventilation depending on the version
Temperature class	F used acc. to B
Type spectrum	<p>General purpose motors</p> <ul style="list-style-type: none"> • Legally specified minimum efficiency levels or NEMA premium efficiency levels • Standard motors for general industrial use • Aluminium or cast-iron case depending on the version <p>Severe duty motors</p> <ul style="list-style-type: none"> • Legally specified minimum efficiency levels or NEMA premium efficiency levels • Cast-iron case • Motors for use under extremely difficult environmental conditions <p>Severe duty IEEE841 motors</p> <ul style="list-style-type: none"> • Efficiency levels required by IEEE that exceed the EPACT act • Motors with increased requirements for use in the petrochemical industry (according to IEEE841) • Cast-iron case <p>Explosion-proof motors</p> <ul style="list-style-type: none"> • Efficiency levels better than or equal to EPACT • Multi label according to Division 1, Class I, Group D and Class II, Groups F&G • Single label according to Division 1, Class I, Groups C&D



Example of NEMA motor, Severe Duty SD100, cast-iron case

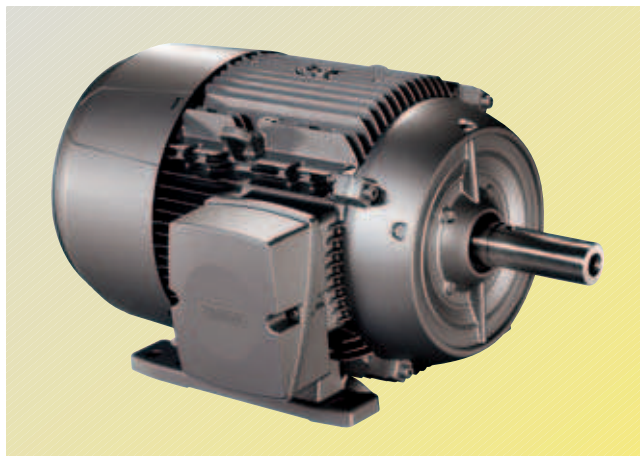

Example of NEMA motor, General Purpose GP10A, aluminium case

Appendix

Siemens contacts worldwide



At

<http://www.siemens.com/automation/partner>

you can find details of Siemens contact partners worldwide responsible for particular technologies.

You can obtain in most cases a contact partner for

- Technical Support,
- Spare parts/repairs,
- Service,
- Training,
- Sales or
- Consultation/engineering.

You start by selecting a

- Country,
- Product or
- Sector.

By further specifying the remaining criteria you will find exactly the right contact partner with his/her respective expertise.



MICROMASTER 420/430/440

Appendix

A&D in the WWW



A detailed knowledge of the range of products and services available is essential when planning and configuring automation systems. It goes without saying that this information must always be fully up-to-date.

The Siemens Automation and Drives Group (A&D) has therefore built up a comprehensive range of information in the World Wide Web, which offers quick and easy access to all data required.

Under the address

<http://www.siemens.com/automation>

you will find everything you need to know about products, systems and services.

Product selection using the Offline Mall of Automation and Drives

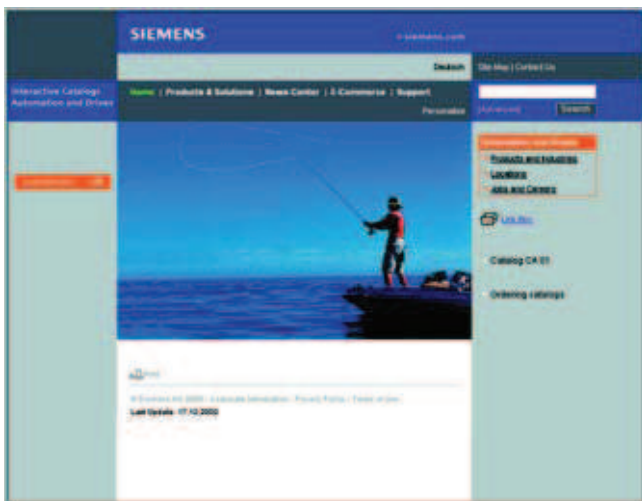

Detailed information together with convenient interactive functions:

The Offline Mall CA 01 covers more than 80,000 products and thus provides a full summary of the Siemens Automation and Drives product base.

Here you will find everything that you need to solve tasks in the fields of automation, switchgear, installation and drives. All information is linked into a user interface which is easy to work with and intuitive.

After selecting the product of your choice you can order at the press of a button, by fax or by online link.

Information on the Offline Mall CA 01 can be found in the Internet under

<http://www.siemens.com/automation/ca01>

or on CD-ROM or DVD.

Easy shopping with the A&D Mall



The A&D Mall is the virtual department store of Siemens AG in the Internet. Here you have access to a huge range of products presented in electronic catalogs in an informative and attractive way.

Data transfer via EDIFACT allows the whole procedure from selection through ordering to tracking of the order to be carried out online via the Internet.

Numerous functions are available to support you.

For example, powerful search functions make it easy to find the required products, which can be immediately checked for availability. Customer-specific discounts and preparation of quotes can be carried out online as well as order tracking and tracing.

Please visit the A&D Mall on the Internet under:

<http://www.siemens.com/automation/mall>



In the face of harsh competition you need optimum conditions to keep ahead all the time: a strong starting position, a sophisticated strategy and team for the necessary support – in every phase. Service & Support from Siemens provides this support with a complete range of different services for automation and drives.

In every phase: from planning and commissioning to maintenance and upgrading.

Our specialists know when and where to act to keep the productivity and cost-effectiveness of your system running in top form.

Online support



The comprehensive information system available round the clock via Internet ranging from Product Support and Service & Support services to Support Tools in the Shop.

<http://www.siemens.com/automation/service&support>

Technical support



Competent consulting in technical questions covering a wide range of customer-oriented services for all our products and systems.

Phone: +49 (0)180 50 50 222
Fax: +49 (0)180 50 50 223
 (0.14 €/min. from the German fixed network)
 E-Mail: adsupport@siemens.com

In the United States, call toll-free:
Phone: +1 800 333 7421
Fax: +1 423 262 2200
 E-Mail: solutions.support@sea.siemens.com

In Canada, call:
Phone: +1 888 303 3353
 E-Mail: cic@siemens.ca

In Asia:
Phone: +86 10 6475 7575
Fax: +86 10 6474 7474
 E-Mail: adsupport.asia@siemens.com

Technical consulting

Support in the planning and designing of your project from detailed actual-state analysis, target definition and consulting on product and system questions right to the creation of the automation solution. ¹⁾

Configuration and software engineering

Support in configuring and developing with customer-oriented services from actual configuration to implementation of the automation project. ¹⁾

Service on site



With service on site we offer services for startup and maintenance, essential for ensuring system availability.

In Germany
Phone: +49 (0)180 50 50 444 ¹⁾
 (0.14 €/min. from the German fixed network)

In the United States, call toll-free:

Phone: +1 800 333 7421

In Canada, call:

Phone: +1 888 303 3353

Repairs and spare parts



In the operating phase of a machine or automation system we provide a comprehensive repair and spare parts service ensuring the highest degree of operating safety and reliability.

In Germany
Phone: +49 (0)180 50 50 448 ¹⁾
 (0.14 €/min. from the German fixed network)

In the United States, call toll-free:

Phone: +1 800 241 4453

In Canada, call:

Phone: +1 888 303 3353

Optimization and upgrading



To enhance productivity and save costs in your project we offer high-quality services in optimization and upgrading. ¹⁾

SPARESonWeb – online spare parts catalog



SPARESonWeb is a web-based tool for selecting the spare parts available for the SINAMICS system. After you have registered and entered the serial number and order number, the spare parts available for the relevant unit are displayed.

The delivery state for specific orders can be displayed for all shipped SINAMICS products.
<http://workplace.automation.siemens.com/sparesonweb>

¹⁾ For country-specific telephone numbers go to our Internet site at: <http://www.siemens.com/automation/service&support>



MICROMASTER 420/430/440

Appendix

Subject index

MICROMASTER

MICROMASTER

	4..	420	430	440		4..	420	430	440
	Page	Page	Page	Page		Page	Page	Page	Page
A					M				
AAOP (operator panel)	-	2/16	-	4/22	Main characteristics	-	2/2	3/2	4/2
AOP (operator panel)	-	2/16	-	4/22	Mechanical features	-	2/3	3/3	4/3
Applications	-	2/2	3/2	4/2	MICROMASTER 411 (overview)	A/17	A/17	A/17	A/17
Assignment table for options	1/4	1/4	1/4	1/4	Motors (overview)	A/14	A/14	A/14	A/14
B					N				
BOP (operator panel)	-	2/16	-	4/22	NEMA motors (overview)	A/18	A/18	A/18	A/18
BOP-2 (operator panel)	-	-	3/16	-	Notes on ordering	A/23	A/23	A/23	A/23
Brake resistor (option)	-	-	-	4/17	O				
C					Online services	A/20	A/20	A/20	A/20
CANopen module	-	2/16	3/16	4/22	Operating instructions	-	2/17	3/18	4/25
CAOP (operator panel)	-	2/16	-	4/22	Operating temperature (derating)	-	2/7	3/7	4/8
CE marking	A/4	A/4	A/4	A/4	Operator panels	1/4	2/16	3/16	4/22
Certificates	A/2	A/2	A/2	A/2	Options	1/4	2/9	3/10	4/12
Chokes (options)	-	2/13	3/14	4/17	Ordering data (inverter)	-	2/8	3/9	4/9
Circuit diagrams	-	2/4	3/4	4/4	Ordering data (options)	-	2/12	3/14	4/16
Circuit-breaker (option)	-	2/14	3/14	4/18	Output chokes (option)	-	2/13	3/14	4/17
COMBIMASTER 411 (overview)	A/17	A/17	A/17	A/17	Overview	1/2	1/2	1/3	1/3
Communications modules	-	2/16	3/16	4/22	P				
Compliance with standards	A/4	A/4	A/4	A/4	Parameter list	-	2/17	3/18	4/25
Conditions of sale and delivery	A/24	A/24	A/24	A/24	Performance features	-	2/3	3/3	4/3
D					PROFIBUS module (option)	-	2/16	3/16	4/22
Demonstration case	A/7	A/7	A/7	A/7	Protection features	-	2/3	3/3	4/3
Derating data	-	2/7	3/7	4/7	Pulse encoder evaluation module (option)	-	-	-	4/22
Description (inverter)	-	2/2	3/2	4/2	Pulse frequency (derating)	-	2/7	3/7	4/7
Description (options)	-	2/9	3/10	4/12	S				
Design	-	2/2	3/2	4/2	Selection and ordering data (inverter)	-	2/8	3/9	4/9
DeviceNet module (option)	-	2/16	3/16	4/22	Selection and ordering data (options)	-	2/11	3/14	4/16
Dimension drawings	-	2/18	3/19	4/26	Selection guide	1/2	1/2	1/3	1/3
Docu pack	-	2/17	3/18	4/25	Service and support	A/21	A/21	A/21	A/21
Documentation	-	2/17	3/18	4/25	SIDEMO (demonstration case system)	A/7	A/7	A/7	A/7
Drive ES	A/6	A/6	A/6	A/6	Siemens contacts worldwide	A/19	A/19	A/19	A/19
Drive ES software	A/6	A/6	A/6	A/6	Sinusoidal filter	-	-	3/14	4/17
DriveMonitor	-	2/15	3/16	4/22	STARTER	-	2/16	3/16	4/22
E					Start-up tools	-	2/15	3/16	4/22
Electromagnetic compatibility	A/5	A/5	A/5	A/5	Support	A/21	A/21	A/21	A/21
EMC filter (option)	-	2/12	3/14	4/16	T				
Environment, resources and recycling	A/2	A/2	A/2	A/2	Technical data (inverter)	-	2/6	3/6	4/6
Export regulations	A/24	A/24	A/24	A/24	Technical data (options)	-	2/10	3/10	4/12
F					Terminal connection diagram	-	2/5	3/5	4/5
Features	-	2/3	3/3	4/3	Terminal connection plates (option)	-	2/14	3/14	4/18
Filter (option)	-	2/12	3/14	4/16	Training	A/8	A/8	A/8	A/8
Fuses (options)	-	2/14	3/14	4/18	U				
G					UL listing	A/5	A/5	A/5	A/5
General circuit diagram	-	2/4	3/4	4/4	V				
Getting Started Guide	-	2/17	3/18	4/25	Variant dependent options	-	2/12	3/14	4/16
I					Variant independent options	-	2/16	3/16	4/22
Installation altitude (derating)	-	2/7	3/8	4/8					
Integration with Drive ES	A/6	A/6	A/6	A/6					
International standards	-	2/2	3/2	4/2					
Internet (online services)	A/20	A/20	A/20	A/20					
L									
LC filter	-	2/13	3/14	4/17					
Line commutating chokes (option)	-	2/13	3/14	4/16					

Order No. index

Notes on ordering

Versions/variants

The last digit of the complete Order No. for the inverters represents the release version.

When ordering, a different digit from the one specified may be present as a result of further technical development.

MICROMASTER

	420	430	440
	Page	Page	Page
3NA3...	2/14	3/14, 3/15	4/18, 4/20
3NE1...	-	3/14, 3/15	4/18, 4/20
3RV10..	2/14	3/14, 3/15	4/18, 4/20
3VL.....	-	3/14, 3/15	4/18, 4/20
6AG1062-1AA..	A/7	-	A/7
6GK1500-0FC00	2/16	3/16	4/22
6SE6400-0AP00-0AA1	2/16	-	4/22
6SE6400-0AP00-0AB0	2/16	-	4/22
6SE6400-0AP00-0CA0	2/16	-	4/22
6SE6400-0BE00-0AA0	-	3/16	-
6SE6400-0BP00-0AA0	2/16	-	4/22
6SE6400-0EN00-0AA0	-	-	4/22
6SE6400-0GP00-0.A0	2/14	3/14	4/18, 4/19
6SE6400-0MD00-0AA0	2/16	-	4/22
6SE6400-0P.00-0AA0	2/16	3/16	4/22
6SE6400-1CB00-0AA0	2/16	3/16	4/22
6SE6400-1DN00-0AA0	2/16	3/16	4/22
6SE6400-1P.00-0AA0	2/16	3/16	4/22
6SE6400-2FA0.	2/12	-	4/16
6SE6400-2FB0.	2/12	-	4/16
6SE6400-2FLO.	2/13	-	4/16
6SE6400-2FS0.	2/12	3/15	4/19
6SE6400-3CC..	2/13	3/14, 3/15	4/16, 4/19
6SE6400-3TC..	2/13	3/14, 3/15	4/17, 4/19
6SE6400-3TD..	2/13	3/14, 3/15	4/17, 4/19
6SE6400-4B...	-	-	4/17, 4/19
6SE6400-5....	2/17	3/18	4/25
6SE6420-2AB..	2/8	-	-
6SE6420-2AC..	2/8	-	-
6SE6420-2AD..	2/8	-	-
6SE6420-2UC..	2/8	-	-
6SE6420-2UD..	2/8	-	-
6SE6430-2AD..	-	3/9	-
6SE6430-2UD..	-	3/9	-
6SE6440-2AB..	-	-	4/11
6SE6440-2AC..	-	-	4/11
6SE6440-2AD..	-	-	4/11
6SE6440-2UC..	-	-	4/9
6SE6440-2UD..	-	-	4/9
6SE6440-2UE..	-	-	4/10
6SL3000-0BE3.	-	3/14	4/16
6SL3000-0CE3.	-	3/14	4/17
6SL3000-2BE..	-	3/14	4/17
6SL3000-2CE..	-	3/14	4/16
6SL3072-0AA0.	2/16	3/16	4/22
6SW1700-0J...	A/6	A/6	A/6
6SW1700-5J...	A/6	A/6	A/6
6SW1700-6J...	A/6	A/6	A/6
6ZB5310-0K...	A/24	A/24	A/24

MICROMASTER 420/430/440

Appendix

Terms and Conditions of Sale and Delivery

By using this catalog you can acquire hardware and software products described therein from Siemens AG subject to the following terms. Please note! The scope, the quality and the conditions for supplies and services, including software products, by any Siemens entity having a registered office outside of Germany, shall be subject exclusively to the General Terms and Conditions of the respective Siemens entity. The following terms apply exclusively for orders placed with Siemens AG.

For customers with a seat or registered office in Germany

The "General Terms of Payment" as well as the "General Conditions for the Supply of Products and Services of the Electrical and Electronics Industry" shall apply.

For software products, the "General License Conditions for Software Products for Automation and Drives for Customers with a Seat or registered Office in Germany" shall apply.

For customers with a seat or registered office outside of Germany

The "General Terms of Payment" as well as the "General Conditions for Supplies of Siemens. Automation and Drives for Customers with a Seat or registered Office outside of Germany" shall apply.

For software products, the "General License Conditions for Software Products for Automation and Drives for Customers with a Seat or registered Office outside of Germany" shall apply.

General

The dimensions are in mm. In Germany, according to the German law on units in measuring technology, data in inches only apply to devices for export.

Illustrations are not binding.

Insofar as there are no remarks on the corresponding pages, - especially with regard to data, dimensions and weights given - these are subject to change without prior notice.

The prices are in € (Euro) ex works, exclusive packaging.

The sales tax (value added tax) is not included in the prices. It shall be debited separately at the respective rate according to the applicable legal regulations.

Prices are subject to change without prior notice. We will debit the prices valid at the time of delivery.

Surcharges will be added to the prices of products that contain silver, copper, aluminum, lead and/or gold if the respective basic official prices for these metals are exceeded. These surcharges will be determined based on the official price and the metal factor of the respective product.

The surcharge will be calculated on the basis of the official price on the day prior to receipt of the order or prior to the release order.

The metal factor determines the official price as of which the metal surcharges are charged and the calculation method used. The metal factor, provided it is relevant, is included with the price information of the respective products.

An exact explanation of the metal factor and the text of the Comprehensive Terms and Conditions of Sale and Delivery are available free of charge from your local Siemens business office under the following Order Nos.:

- 6ZB5310-0KR30-0BA1
(for customers based in Germany)
- 6ZB5310-0KS53-0BA1
(for customers based outside Germany)

or download them from the Internet
<http://www.siemens.com/automation/mall>
(Germany: A&D Mall Online-Help System)

Export regulations

The products listed in this catalog may be subject to European / German and/or US export regulations.

Therefore, any export requiring a license is subject to approval by the competent authorities.

According to current provisions, the following export regulations must be observed with respect to the products featured in this catalog:

AL	<p>Number of the <u>German Export List</u></p> <p>Products marked other than "N" require an export license.</p> <p>In the case of software products, the export designations of the relevant data medium must also be generally adhered to.</p> <p>Goods labeled with an <u>"AL" not equal to "N"</u> are subject to a European or German export authorization when being exported out of the EU.</p>
ECCN	<p><u>Export Control Classification Number</u></p> <p>Products marked other than "N" are subject to a reexport license to specific countries.</p> <p>In the case of software products, the export designations of the relevant data medium must also be generally adhered to.</p> <p>Goods labeled with an <u>"ECCN" not equal to "N"</u> are subject to a US re-export authorization.</p>

Even without a label or with an "AL: N" or "ECCN: N", authorization may be required due to the final destination and purpose for which the goods are to be used.

The deciding factors are the AL or ECCN export authorization indicated on order confirmations, delivery notes and invoices.

Errors excepted and subject to change without prior notice.

A&D/VuL_ohne MZ/En 05.09.06

Catalogs of the Automation and Drives Group (A&D)

Further information can be obtained from our branch offices listed in the appendix or at www.siemens.com/automation/partner

Automation and Drives	<i>Catalog</i>	Industrial Communication for Automation and Drives	<i>Catalog</i> IK PI
Interactive catalog on CD-ROM and on DVD			
• The Offline Mall of Automation and Drives	CA 01		
Automation Systems for Machine Tools		Low-Voltage	
SINUMERIK & SIMODRIVE	NC 60	Controls and Distribution – SIRIUS, SENTRON, SIVACON	LV 1
SINUMERIK & SINAMICS	NC 61	Controls and Distribution – Technical Information	LV 1 T
		SIRIUS, SENTRON, SIVACON	
		SIDAC Reactors and Filters	LV 60
		SIVENT Fans	LV 65
		SIVACON 8PS Busbar Trunking Systems	LV 70
Drive Systems		Motion Control System SIMOTION	PM 10
<u>Variable-Speed Drives</u>			
SINAMICS G110/SINAMICS G120	D 11.1	Process Instrumentation and Analytics	
Inverter Chassis Units		Field Instruments for Process Automation	FI 01
SINAMICS G120D		Measuring Instruments for Pressure, Differential Pressure, Flow, Level and Temperature, Positioners and Liquid Meters	
Distributed Frequency Inverters		<i>PDF: Indicators for panel mounting</i>	MP 12
SINAMICS G130 Drive Converter Chassis Units, SINAMICS G150 Drive Converter Cabinet Units	D 11	SIREC Recorders and Accessories	MP 20
SINAMICS GM150/SINAMICS SM150	D 12	SIPART, Controllers and Software	MP 31
Medium-Voltage Converters		SIWAREX Weighing Systems	WT 01
SINAMICS S120 Drive Converter Systems	D 21.1	Continuous Weighing and Process Protection	WT 02
SINAMICS S150 Drive Converter Cabinet Units	D 21.3	Process Analytical Instruments	PA 01
Asynchronous Motors Standardline	D 86.1	<i>PDF: Process Analytics, Components for the System Integration</i>	PA 11
Synchronous Motors with Permanent-Magnet Technology, HT-direct	D 86.2		
DC Motors	DA 12	SIMATIC Industrial Automation Systems	
SIMOREG DC MASTER 6RA70 Digital Chassis Converters	DA 21.1	SIMATIC PCS Process Control System	ST 45
SIMOREG K 6RA22 Analog Chassis Converters	DA 21.2	Products for Totally Integrated Automation and Micro Automation	ST 70
SIMOREG DC MASTER 6RM70 Digital Converter Cabinet Units	DA 22	SIMATIC PCS 7 Process Control System	ST PCS 7
SIMOVERT PM Modular Converter Systems	DA 45	Add-ons for the SIMATIC PCS 7 Process Control System	ST PCS 7.1
SIEMOSYN Motors	DA 48	Migration solutions with the SIMATIC PCS 7 Process Control System	ST PCS 7.2
MICROMASTER 410/420/430/440 Inverters	DA 51.2	pc-based Automation	ST PC
MICROMASTER 411/COMBIMASTER 411	DA 51.3	SIMATIC Control Systems	ST DA
SIMOVERT MASTERDRIVES Vector Control	DA 65.10		
SIMOVERT MASTERDRIVES Motion Control	DA 65.11	SIMATIC Sensors	
Synchronous and asynchronous servomotors for SIMOVERT MASTERDRIVES	DA 65.3	Sensors for Factory Automation	FS 10
SIMODRIVE 611 universal and POSMO	DA 65.4		
<u>Low-Voltage Three-Phase-Motors</u>		Systems Engineering	
IEC Squirrel-Cage Motors	D 81.1	Power supplies SITOP power	KT 10.1
<u>Automation Systems for Machine Tools SIMODRIVE</u>	NC 60	System cabling SIMATIC TOP connect	KT 10.2
• Main Spindle/Feed Motors			
• Converter Systems SIMODRIVE 611/POSMO		System Solutions	
<u>Automation Systems for Machine Tools SINAMICS</u>	NC 61	Applications and Products for Industry are part of the interactive catalog CA 01	
• Main Spindle/Feed Motors			
• Drive System SINAMICS S120		TELEPERM M Process Control System	
<u>Drive and Control Components for Hoisting Equipment</u>	HE 1	<i>PDF: AS 488/TM automation systems</i>	PLT 112
Electrical Installation Technology			
<i>PDF: ALPHA Small Distribution Boards and Distribution Boards, Terminal Blocks</i>	ETA 1		
<i>PDF: ALPHA 8HP Molded-Plastic Distribution System</i>	ETA 3		
<i>PDF: BETA Low-Voltage Circuit Protection</i>	ET B1		
<i>PDF: DELTA Switches and Socket Outlets</i>	ET D1		
GAMMA Building Controls	ET G1		
Human Machine Interface Systems SIMATIC HMI	ST 80		

PDF: These catalogs are only available as pdf files.